

Data sheet

750-613

POWER SUPPLY PASSIVE CARRIER RAIL DIN 35 CAGE CLAMP CONNECTION



Technical data

Package size 1 piece.

Voltage supply	DC 24 V (-25% / + 30%)
Current supply (typ)	500 mA
Total current for I/O modules	2000 mA
Voltage supply via power jumper contacts (max)	DC 24 V (-25% / + 30%)
Current via power jumper contacts (max)	DC 10 A
Operating temperature	0 °C ... + 55 °C
Storage temperature	-25 °C ... +85 °C
Relative air humidity	95 %
Vibration resistance	acc. IEC 60068-2-6
Shock resistance	acc. IEC 60068-2-27
Degree of protection	IP 20
EMC immunity to interference	acc. EN 50082-2 (96)
EMC emission of interference	per EN 50081-1 (93)
UL 508	E175199, UL 508
EMC marine applications - noise proof	gem. Germanischer Lloyd (1997)
UL 1604	E198726, UL 1604 Class 1 Dev2 ABCD T4A
EMC marine applications - noise transmission	gem. Germanischer Lloyd (1997)
KEMA	01ATEX1024X Eex nA II T4
Conformity marking	CE
Cross section from [mm ²]	0.08 mm ²
Cross section to [mm ²]	2.5 mm ²
Cross section from [AWG]	28 AWG
Cross section to [AWG]	14 AWG

Data sheet**750-613****POWER SUPPLY PASSIVE
CARRIER RAIL DIN 35 CAGE CLAMP CONNECTION**

Voltage CSA	24 V
Current rating CSA	10 A
Weight	58.5 g
Color	light gray
Height	64 mm
Height	2.52 in
Width	12 mm
Width	0.472 in
Depth	100 mm
Depth	3.937 in
Strip length from	8 mm
Strip length to	9 mm
Strip length	0.33 in

Data sheet

750-613

**POWER SUPPLY PASSIVE
CARRIER RAIL DIN 35 CAGE CLAMP CONNECTION**

Approval	Voltage	Current	Approval number	Notes
BV			13453/A0BV	
CSA	24	10	154112-1043296	
cULus	24	10	E175199	
cULus-EX	24	10	E198726	
DNV			A-8471	
GL			40197-01HH	
KEMA-Ex			KEMA00ATEX1024U	
LR			02/20036	
Rina			MAC30402CS1	

Data sheet

750-613

POWER SUPPLY PASSIVE CARRIER RAIL DIN 35 CAGE CLAMP CONNECTION

Accessories	Item number
ALUMINUM CARRIER RAIL 35 X 7.5 MM, 1.5 MM / 0.059 IN THICK	210-196
CAL FIELDBUS COUPLER 10 kBaud - 1 MBaud	750-305
CANopen ECO FIELDBUS COUPLER D-Sub 10 kBaud - 1 MBaud	750-348
CANopen ECO FIELDBUS COUPLER MSS 10 kBaud - 1 MBaud	750-347
CANopen FIELDBUS COUPLER 10 kBaud - 1 MBaud	750-307
CANopen FIELDBUS COUPLER 10 kBaud - 1 MBaud	750-337
CANopen FIELDBUS COUPLER WITH D-SUB	750-338
CANopen PROGRAMMABLE FIELDBUS CONTROLLER 10 kBaud - 1 MBaud	750-837
CANopen PROGRAMMABLE FIELDBUS CONTROLLER WITH D-SUB	750-838
CC-LINK 156 kBaud - 10 MBaud	750-310
COPPER CARRIER RAIL 35 X 15 MM, 2.3 MM / 0.091 IN THICK	210-198
DeviceNet ECO FIELDBUS COUPLER 125-500 kBaud	750-346
DeviceNet FIELDBUS COUPLER 125-500 kBaud	750-306
DEVICENET PROGRAMMABLE FIELDBUS -CONTROLLER 125-500 kBaud	750-806
END MODULE CARRIER RAIL DIN 35	750-600
ETHERNET TCP/IP FIELDBUS COUPLER 10 MBit/s	750-342
ETHERNET TCP/IP FIELDBUS COUPLER 10/100 Mbit/s	750-341
FIRE WIRE FIELDBUS COUPLER DIGITAL AND ANALOG SIGNALS	750-339
I/O-LIGHTBUS FIELDBUS COUPLER 2.5 MBaud	750-300
I/O-LIGHTBUS FIELDBUS COUPLER 2.5 MBaud	750-320
Individual wire jumpers	individual jumper
INTERBUS ECO FIELDBUS COUPLER 2 MBaud	750-345
INTERBUS ECO FIELDBUS COUPLER 500 kBaud	750-344
INTERBUS FIELDBUS COUPLER 500 kBaud	750-324
INTERBUS FIELDBUS COUPLER DIGITAL AND ANALOG SIGNALS	750-304
INTERBUS FIELDBUS COUPLER DIGITAL AND ANALOG SIGNALS	750-334
INTERBUS PROGRAMMABLE FIELDBUS CONTROLLER DIGITAL AND ANALOG SIGNALS	750-804
IP65 ENCLOSURE SHEET STEEL	850-811
IP65 ENCLOSURE SHEET STEEL	850-812
IP65 ENCLOSURE SHEET STEEL	850-813
LON FIELDBUS COUPLER 78 kbps	750-319
LONWORKS PROGRAMMABLE FIELDBUS COUPLER 78 kbps	750-819
MARKERS FOR GROUP MARKER CARRIERS MARKER CARD DIN A4 (160 MARKERS)	750-100
MINIATURE WSB QUICK MARKING STRIPS PLAIN	248-501
MINIATURE WSB QUICK MARKING STRIPS PLAIN	248-501/000-002
MINIATURE WSB QUICK MARKING STRIPS PLAIN	248-501/000-005
MINIATURE WSB QUICK MARKING STRIPS PLAIN	248-501/000-006
MINIATURE WSB QUICK MARKING STRIPS PLAIN	248-501/000-007
MINIATURE WSB QUICK MARKING STRIPS PLAIN	248-501/000-012

Data sheet

750-613

POWER SUPPLY PASSIVE CARRIER RAIL DIN 35 CAGE CLAMP CONNECTION

MINIATURE WSB QUICK MARKING STRIPS PLAIN	248-501/000-017
MINIATURE WSB QUICK MARKING STRIPS PLAIN	248-501/000-023
MINIATURE WSB QUICK MARKING STRIPS PLAIN	248-501/000-024
MODBUS FIELDBUS COUPLER RS 232 / 1,2 - 115,2 kBaud	750-316
MODBUS FIELDBUS COUPLER RS 232 / 150 - 19200 Baud	750-314
MODBUS FIELDBUS COUPLER RS 485 / 1,2 - 115,2 kBaud	750-315
MODBUS FIELDBUS COUPLER RS 485 / 150 - 19200 Baud	750-312
MODBUS PROGRAMMABLE FIELDBUS CONTROLLER RS 232 / 1,2 - 115,2 kBaud	750-816
MODBUS PROGRAMMABLE FIELDBUS CONTROLLER RS 232 / 150 - 19200 Baud	750-814
MODBUS PROGRAMMABLE FIELDBUS CONTROLLER RS 485 / 1,2 - 115,2 kBaud	750-815
MODBUS PROGRAMMABLE FIELDBUS CONTROLLER RS 485 / 150 - 19200 Baud	750-812
MODULE BUS EXTENSION, COUPLER MODULE	750-628
MODULE BUS EXTENSION, END MODULE	750-627
MP-BUS (MULTI POINT-BUS) MASTER MODULE CARRIER RAIL DIN 35	750-643
Open individual wire jumpers ends	individual jumper open end
POWER SUPPLY UNIT PRIMARY TRIGGERED	787-903
POWER SUPPLY UNIT PRIMARY TRIGGERED	787-904
POWER SUPPLY UNIT PRIMARY TRIGGERED	787-912
PROFIBUS DP ECO FIELDBUS COUPLER 12 MBaud	750-343
PROFIBUS DP FIELDBUS COUPLER 1,5 MBaud	750-331
PROFIBUS DP FIELDBUS COUPLER 12 MBaud	750-323
PROFIBUS DP/FMS FIELDBUS COUPLER 1,5 MBaud	750-301
PROFIBUS DP/FMS FIELDBUS COUPLER 12 MBaud	750-303
PROFIBUS DP/V1 FIELDBUS COUPLER 12 MBaud	750-333
PROFIBUS DP/V1 PROGRAMMABLE FIELDBUS CONTROLLER 12 MBaud	750-833
RADIO RECEIVER MODULE CARRIER RAIL DIN 35	750-642
RAIL-MOUNTED MODULES - POWER SUPPLYUNITS WITH UNIVERSAL MOUNTING CARRIER	288-808
RAIL-MOUNTED MODULES - POWER SUPPLYUNITS WITH UNIVERSAL MOUNTING CARRIER	288-809
RAIL-MOUNTED MODULES - POWER SUPPLYUNITS WITH UNIVERSAL MOUNTING CARRIER	288-810
RAIL-MOUNTED MODULES - POWER SUPPLYUNITS WITH UNIVERSAL MOUNTING CARRIER	288-812
RAIL-MOUNTED MODULES - POWER SUPPLYUNITS WITH UNIVERSAL MOUNTING CARRIER	288-813
RAIL-MOUNTED MODULES - POWER SUPPLYUNITS WITH UNIVERSAL MOUNTING CARRIER	288-814
RAIL-MOUNTED MODULES - POWER SUPPLYUNITS WITH UNIVERSAL MOUNTING CARRIER	288-815
SCREWDRIVER Type 1, bar (2,5 x 0,4) mm	210-119

Data sheet

750-613

POWER SUPPLY PASSIVE CARRIER RAIL DIN 35 CAGE CLAMP CONNECTION

SCREWDRIVER Type 2, bar (3,5 x 0,5) mm	210-120
SCREWDRIVER WITH PARTIALLY INSULATED SHAFT Type 1, bar (2,5 x 0,4) mm	210-619
SCREWDRIVER WITH PARTIALLY INSULATED SHAFT Type 2, bar (3,5 x 0,5) mm	210-620
SCREWLESS END STOP 10 MM / 0.394 IN WIDE	249-117
SDS FIELDBUS COUPLER DIGITAL AND ANALOG SIGNALS	750-313
SHIELD CLAMPING SADDLE 11 MM / 0.433 IN WIDE	790-108
SHIELD CLAMPING SADDLE 19 MM / 0.741 IN WIDE	790-116
SHIELD CLAMPING SADDLE 27 MM / 1.053 IN WIDE	790-124
SHIELD CLAMPING SADDLE 43 MM / 1.677 IN WIDE	790-140
STEEL CARRIER RAIL 35 X 15 MM, 1.5 MM / 0.059 IN THICK	210-114
STEEL CARRIER RAIL 35 X 15 MM, 1.5 MM / 0.059 IN THICK	210-197
STEEL CARRIER RAIL 35 X 15 MM, 1.5 MM / 0.059 IN THICK	210-506
STEEL CARRIER RAIL 35 X 15 MM, 1.5 MM / 0.059 IN THICK	210-508
STEEL CARRIER RAIL 35 X 15 MM, 2.3 MM / 0.091 IN THICK	210-118
STEEL CARRIER RAIL 35 X 15 MM, 2.3 MM / 0.091 IN THICK	210-548
STEEL CARRIER RAIL 35 X 7.5 MM, 1 MM / 0.039 IN THICK	210-112
STEEL CARRIER RAIL 35 X 7.5 MM, 1 MM / 0.039 IN THICK	210-113
STEEL CARRIER RAIL 35 X 7.5 MM, 1 MM / 0.039 IN THICK	210-504
STEEL CARRIER RAIL 35 X 7.5 MM, 1 MM / 0.039 IN THICK	210-505
STEEL IP65 ENCLOSURES 10 MBit/s	750-842
STEEL IP65 ENCLOSURES 10/100 Mbit/s	750-841
STÜTZELKO-MODUL SMOOTHES UNSTABLE DC 24 V POWER SUPPLIES	288-824

Data sheet

750-613

POWER SUPPLY PASSIVE CARRIER RAIL DIN 35 CAGE CLAMP CONNECTION

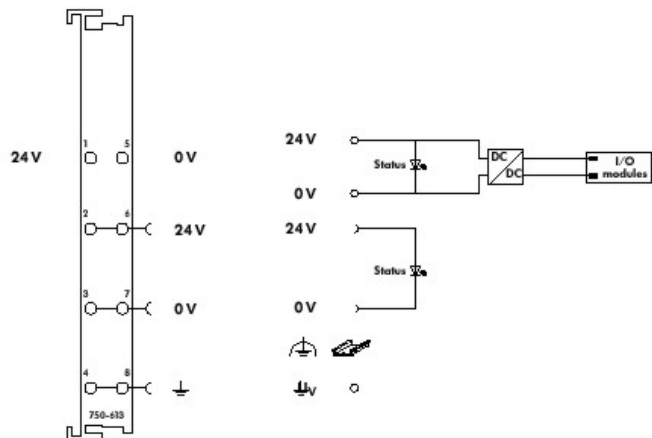
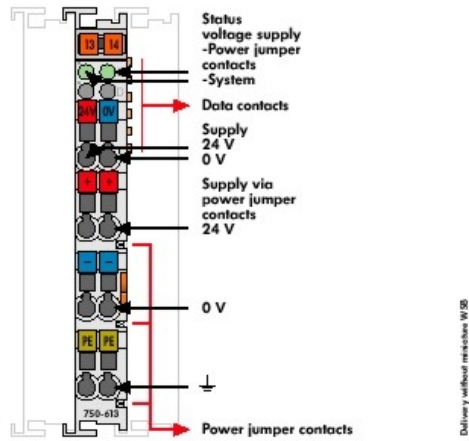

Data sheet**750-613****POWER SUPPLY PASSIVE
CARRIER RAIL DIN 35 CAGE CLAMP CONNECTION**

The internal system supply module increases the current supply for the internal 5 V DC system by 2 A. If the the internal current consumption of all modules is higher than 2 A, an additional supply module must be added.

The supply module also supplies field side power to the adjoining modules via the power jumper contacts.