

Data sheet

750-304

INTERBUS FIELDBUS COUPLER DIGITAL AND ANALOG SIGNALS CAGE CLAMP CONNECTION



Technical data

Package size 1 piece.

Max. no. of nodes	256
Max. no. Of I/O points	4096 (depends on Master)
Transmission medium	certified Cu cable
Max. length of fieldbus segment	400 m
Data transmission rate (kBaud)	500 kBaud
Transmission time	typ. 1.43 ms (10 Module; 32 I, 32 O/Mod)
Buscoupler connection	1 x D-SUB 9; plug for input interface 1 x D-SUB 9; socket for output interface
UL 508	E175199, UL 508
UL 1604	E198726, UL 1604 Class 1 Dev2 ABCD T4A
KEMA	01ATEX1024X Eex nA II T4
Standard	EN 50254
Certification	INTERBUS CLUB
Conformity marking	CE
Max. no. of I/O modules	64
Max. fieldbus input image (Byte)	64 Byte
Max. fieldbus output image (Byte)	64 Byte
Configuration	via PC or PLC
Voltage supply	DC 24 V (-15% / + 20%)
Input current (max)	500 mA
Efficiency of the power supply	87 %
Internal current consumption	300 mA
Total current for the I/O modules	1700 mA

Data sheet

750-304

INTERBUS FIELDBUS COUPLER DIGITAL AND ANALOG SIGNALS CAGE CLAMP CONNECTION

Isolation	500 V system / supply
Voltage via power jumper contacts (max)	DC 24 V (-15% / + 20%)
Current via power jumper contacts (max)	DC 10 A
Operating temperature	0 °C ... + 55 °C
Storage temperature	-25 °C ... +85 °C
Relative air humidity	95 %
Vibration resistance	acc. IEC 60068-2-6
Shock resistance	acc. IEC 60068-2-27
Degree of protection	IP 20
EMC immunity to interference	acc. EN 50082-2 (96)
EMC emission of interference	acc. EN 50081-2 (94)
Cross section from [mm ²]	0.08 mm ²
Cross section to [mm ²]	2.5 mm ²
Cross section from [AWG]	28 AWG
Cross section to [AWG]	14 AWG
Voltage CSA	24 V
Weight	192 g
Color	light gray
Height	65 mm
Height	2.56 in
Width	51 mm
Width	2.008 in
Depth	100 mm
Depth	3.937 in
Strip length from	8 mm
Strip length to	9 mm
Strip length	0.33 in
Manuals	

Data sheet

750-304

**INTERBUS FIELDBUS COUPLER DIGITAL AND ANALOG SIGNALS
CAGE CLAMP CONNECTION**

Approval	Voltage	Current	Approval number	Notes
CSA	24		154112-1043296	
cULus	24		E175199	
cULus-EX	24		E198726	
KEMA-Ex			KEMA00ATEX1024U	

Data sheet

750-304

INTERBUS FIELD BUS COUPLER DIGITAL AND ANALOG SIGNALS CAGE CLAMP CONNECTION

Accessories	Item number
ALUMINUM CARRIER RAIL 35 X 7.5 MM, 1.5 MM / 0.059 IN THICK	210-196
COMMUNICATION CABLE	750-920
COPPER CARRIER RAIL 35 X 15 MM, 2.3 MM / 0.091 IN THICK	210-198
END MODULE CARRIER RAIL DIN 35	750-600
Individual wire jumpers	individual jumper
INTERBUS FIELD BUS PLUG (IN) WITH D-SUB FEMALE CONNECTOR	750-961
INTERBUS FIELD BUS PLUG (OUT) WITH D-SUB-PLUG	750-962
IP65 ENCLOSURE SHEET STEEL	850-811
IP65 ENCLOSURE SHEET STEEL	850-812
IP65 ENCLOSURE SHEET STEEL	850-813
MARKERS FOR GROUP MARKER CARRIERS MARKER CARD DIN A4 (160 MARKERS)	750-100
MINIATURE WSB QUICK MARKING STRIPS PLAIN	248-501
MINIATURE WSB QUICK MARKING STRIPS PLAIN	248-501/000-002
MINIATURE WSB QUICK MARKING STRIPS PLAIN	248-501/000-005
MINIATURE WSB QUICK MARKING STRIPS PLAIN	248-501/000-006
MINIATURE WSB QUICK MARKING STRIPS PLAIN	248-501/000-007
MINIATURE WSB QUICK MARKING STRIPS PLAIN	248-501/000-012
MINIATURE WSB QUICK MARKING STRIPS PLAIN	248-501/000-017
MINIATURE WSB QUICK MARKING STRIPS PLAIN	248-501/000-023
MINIATURE WSB QUICK MARKING STRIPS PLAIN	248-501/000-024
Open individual wire jumpers ends	individual jumper open end
POWER SUPPLY UNIT PRIMARY TRIGGERED	787-903
POWER SUPPLY UNIT PRIMARY TRIGGERED	787-904
POWER SUPPLY UNIT PRIMARY TRIGGERED	787-912
PROFINET IO FIELD BUS COUPLER 100 Mbit	750-340
PROFINET PROGRAMMABLE FIELD BUS CONTROLLER 100 Mbit	750-840
RAIL-MOUNTED MODULES - POWER SUPPLY UNITS WITH UNIVERSAL MOUNTING CARRIER	288-808
RAIL-MOUNTED MODULES - POWER SUPPLY UNITS WITH UNIVERSAL MOUNTING CARRIER	288-809
RAIL-MOUNTED MODULES - POWER SUPPLY UNITS WITH UNIVERSAL MOUNTING CARRIER	288-810
RAIL-MOUNTED MODULES - POWER SUPPLY UNITS WITH UNIVERSAL MOUNTING CARRIER	288-812
RAIL-MOUNTED MODULES - POWER SUPPLY UNITS WITH UNIVERSAL MOUNTING CARRIER	288-813
RAIL-MOUNTED MODULES - POWER SUPPLY UNITS WITH UNIVERSAL MOUNTING CARRIER	288-814
RAIL-MOUNTED MODULES - POWER SUPPLY UNITS WITH UNIVERSAL MOUNTING CARRIER	288-815

Data sheet

750-304

INTERBUS FIELDBUS COUPLER DIGITAL AND ANALOG SIGNALS CAGE CLAMP CONNECTION

SCREWDRIVER Type 1, bar (2,5 x 0,4) mm	210-119
SCREWDRIVER Type 2, bar (3,5 x 0,5) mm	210-120
SCREWDRIVER WITH PARTIALLY INSULATED SHAFT Type 1, bar (2,5 x 0,4) mm	210-619
SCREWDRIVER WITH PARTIALLY INSULATED SHAFT Type 2, bar (3,5 x 0,5) mm	210-620
SCREWLESS END STOP 10 MM / 0.394 IN WIDE	249-117
SHIELD CLAMPING SADDLE 11 MM / 0.433 IN WIDE	790-108
SHIELD CLAMPING SADDLE 19 MM / 0.741 IN WIDE	790-116
SHIELD CLAMPING SADDLE 27 MM / 1.053 IN WIDE	790-124
SHIELD CLAMPING SADDLE 43 MM / 1.677 IN WIDE	790-140
STEEL CARRIER RAIL 35 X 15 MM, 1.5 MM / 0.059 IN THICK	210-114
STEEL CARRIER RAIL 35 X 15 MM, 1.5 MM / 0.059 IN THICK	210-197
STEEL CARRIER RAIL 35 X 15 MM, 1.5 MM / 0.059 IN THICK	210-506
STEEL CARRIER RAIL 35 X 15 MM, 1.5 MM / 0.059 IN THICK	210-508
STEEL CARRIER RAIL 35 X 15 MM, 2.3 MM / 0.091 IN THICK	210-118
STEEL CARRIER RAIL 35 X 15 MM, 2.3 MM / 0.091 IN THICK	210-548
STEEL CARRIER RAIL 35 X 7.5 MM, 1 MM / 0.039 IN THICK	210-112
STEEL CARRIER RAIL 35 X 7.5 MM, 1 MM / 0.039 IN THICK	210-113
STEEL CARRIER RAIL 35 X 7.5 MM, 1 MM / 0.039 IN THICK	210-504
STEEL CARRIER RAIL 35 X 7.5 MM, 1 MM / 0.039 IN THICK	210-505
STEEL IP65 ENCLOSURES 10/100 Mbit/s	750-841/025-000
STEPPER MODULE FOR THE WAGO-I/O-SYSTEM 750	750-670
STÜTZELKO-MODUL SMOOTHES UNSTABLE DC 24 V POWER SUPPLIES	288-824
WAGO RADIO ADAPTER	750-921

Data sheet

750-304

INTERBUS FIELDBUS COUPLER DIGITAL AND ANALOG SIGNALS CAGE CLAMP CONNECTION

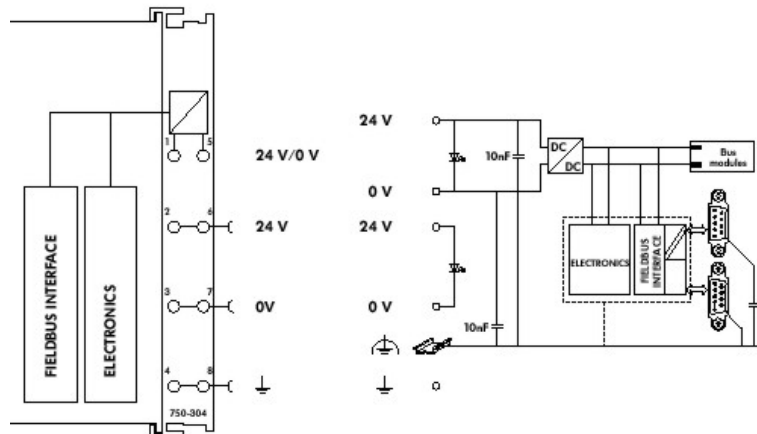
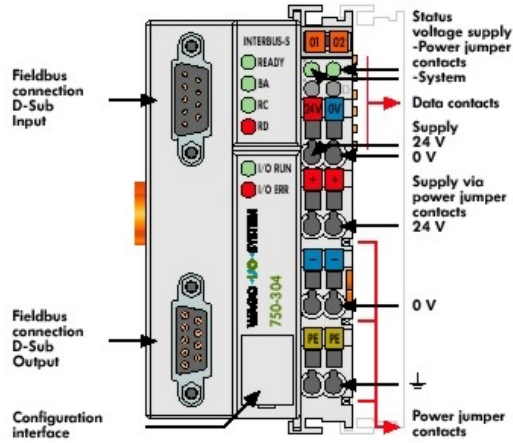

Data sheet**750-304****INTERBUS FIELDBUS COUPLER DIGITAL AND ANALOG SIGNALS
CAGE CLAMP CONNECTION**

This buscoupler allows connection of the WAGO-I/O-SYSTEM as a slave to the INTERBUS fieldbus.

The buscoupler is capable of supporting all bus modules. The buscoupler automatically configures, creating a local process image which may include analog, digital or specialty modules. Analog and specialty module data is sent via words and/or bytes, digital data is sent bit by bit.

INTERBUS allows the storing of the process image in the corresponding Master control (PLC, PC or NC).

The local process image is divided into two data zones containing the data received and the data to be sent. The process data can be sent via the INTERBUS fieldbus to the PLC, PC or NC for further processing, and received from the field via INTERBUS.

The data of the analog modules is stored in the process image which is created automatically according to the order in which the modules are connected to the buscoupler. The bits of the digital modules are sent byte by byte and added to the analog data. If the amount of digital information exceeds 8 bits, the buscoupler automatically starts with a new byte.

Data sheet

750-304

**INTERBUS FIELDBUS COUPLER DIGITAL AND ANALOG SIGNALS
CAGE CLAMP CONNECTION**
