



MADE IN  
USA

## ATR SERIES Current Transducers

### Applications

#### VFD Controlled Loads

- Monitoring VFD output indicates how the motor and attached load are operating.

#### SCR Controlled Loads

- Accurate measurement of phase angle fired or burst fired (time proportioned) SCRs.
- Current measurement gives faster response than temperature measurement.

#### Switching Power Supplies and Electronic Ballasts

- True RMS sensing is the most accurate way to measure power supply or ballast input power.

### Current Transformer Monitoring

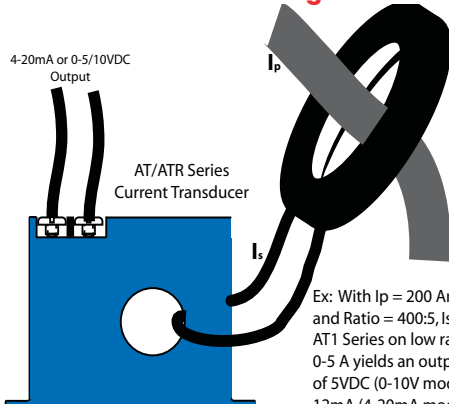

Ex: With  $I_p = 200$  Amps and Ratio = 400:5,  $I_s = 2.5$  A  
AT1 Series on low range 0-5 A yields an output of 5VDC (0-10V model) or 12mA (4-20mA model)

**ATR Series** Current Transducers combine a current transformer and a True RMS signal conditioner into a single package. The ATR Series provides True RMS output on distorted waveforms found on VFD or SCR outputs, and on linear loads in “noisy” power environments. Available in a solid- or split-core case.

### Features

#### True RMS Output

- True RMS technology is accurate on distorted waveforms like VFD or SCR outputs.

#### Jumper Selectable Ranges

- Reduces inventory.
- Eliminates zero and span pots.

#### Isolation

- Output is magnetically isolated from the input for safety.
- Eliminates insertion loss (voltage drop).

#### UL, CUL and CE Approval

- Accepted worldwide.

### Selecting the right transducer:

The current waveform of a typical linear load is a pure sine wave. In VFD and SCR applications, however, output waveforms are rough approximations of a sine wave. There are numerous spikes and dips in each cycle. ATR transducers use a mathematical algorithm called “True RMS” which integrates the actual waveform over time. The output is the average component of the true power (heating value) of the AC current waveform. True RMS is the only way to accurately measure distorted AC waveforms.

**Select ATR transducers for nonlinear loads in “noisy” power environments.**



## Dimensions

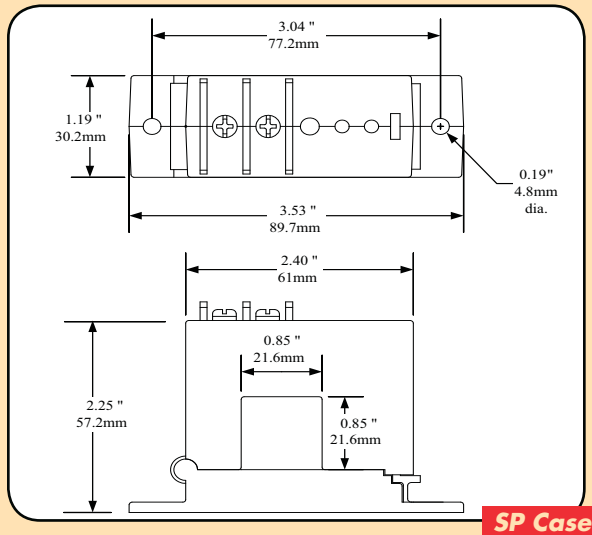
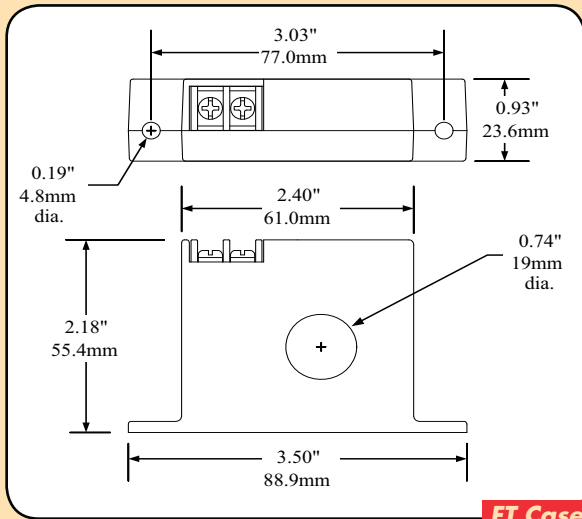

## Connections

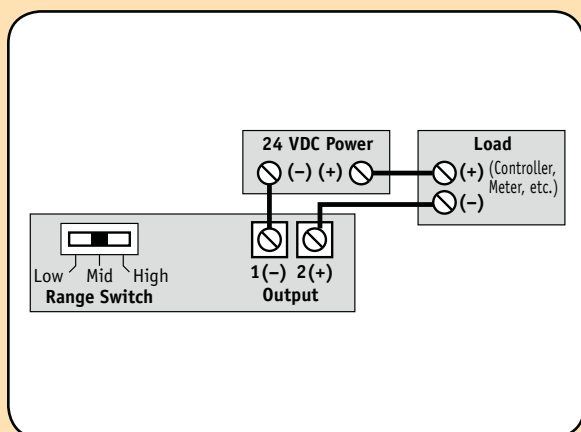

**Notes:** Deadfront captive screw terminals (-SP case).  
12-22 AWG solid or stranded.  
Observe polarity.

## Specifications

<b>Output Signal</b>	4–20mA, Loop-powered, True RMS
<b>Output Limit</b>	23mA
<b>Accuracy</b>	1.0% FS
<b>Response Time</b>	600 ms (to 90% step change)
<b>Frequency Range</b>	10–400Hz
<b>Power Supply</b>	24VDC Nominal, 40VDC Maximum
<b>Isolation Voltage</b>	UL listed to 1,270VAC (tested to 5KV)
<b>Input Ranges</b>	Field selectable ranges from 0–200A; custom ranges available; consult factory.
<b>Sensing Aperture</b>	<ul style="list-style-type: none"> <li>● -FT Case: 0.74" (19mm) dia.</li> <li>● -SP Case: 0.85" (21.6mm) sq.</li> </ul>
<b>Case</b>	UL94 V0 Flammability Rated
<b>Environmental</b>	-4 to 122°F (-20 to 50°C) 0–95% RH, non-condensing
<b>Listings</b>	UL 508 Industrial Control Equipment (USA & Canada), CE



## Ordering Information

Sample Model Number: ATR1-420-24L-SP  
True RMS AC current transducer, 10/20/50A ranges, 4–20mA output, 24VDC loop-powered in a split-core case.

(1) (2) (3) (4)  
ATR  -  - L -

### (1) Full Scale Range

0	2 & 5A
1	10, 20, 50A
2	100, 150, 200A

### (2) Output Signal

420	4–20mA
-----	--------

### (3) Power Supply

24L	24VDC Loop-powered (4-20mA output ONLY)
-----	---

### (4) Case Style

FT	Solid-core, Top Term.
SP	Split-core