

Heavy Duty Terminal Blocks

1700 Series

600 Volts AC/DC (UL/CSA)

1000 Volts (CE)



1708 SC



1708 STD

Specifications:

- Base, Thermoplastic, 125°C (UL RTI)
- Serrated Connectors, Brass, Nickel Plated
- Screws, Brass, Nickel Plated, 10-32
- Current rated up to 30 Amps with unprepared wire, #10-22 AWG Copper
- Current rated up to 75 Amps when wired with crimp type ring, spade or fork lugs
- 5/8" (.625") Line To Line Spacing
- UL Recognized File No. XCFR2.E62806
- CSA Certified File No. LR19766
- CE
- RoHS Compliant

# of Poles	Standard Terminal	Short Circuit Terminal	Dimensions		Clear Cover
			A	B	
2	1702 STD	1702 SC	2.00	1.64	CC 1702
3	1703 STD	1703 SC	2.63	2.26	CC 1703
4	1704 STD	1704 SC	3.25	2.89	CC 1704
5	1705 STD	1705 SC	3.88	3.51	CC 1705
6	1706 STD	1706 SC	4.50	4.14	CC 1706
7	1707 STD	1707 SC	5.13	4.76	CC 1707
8	1708 STD	1708 SC	5.75	5.39	CC 1708
9	1709 STD	1709 SC	6.38	6.01	CC 1709
10	1710 STD	1710 SC	7.00	6.64	CC 1710
11	1711 STD	1711 SC	7.63	7.26	CC 1711
12	1712 STD	1712 SC	8.25	7.89	CC 1712



1700 series optional clear cover

STD = Standard Terminal - Connector Plate, 2 Phil-Slot Screws, Center M/S

mm = dim X 25.4

SC = Short Circuit Terminal (Pin to be torqued to 5 in-lbs)

CC = Clear PVC snap on cover, sized to fit and protect

See page 35 for DIN Rail Adapter

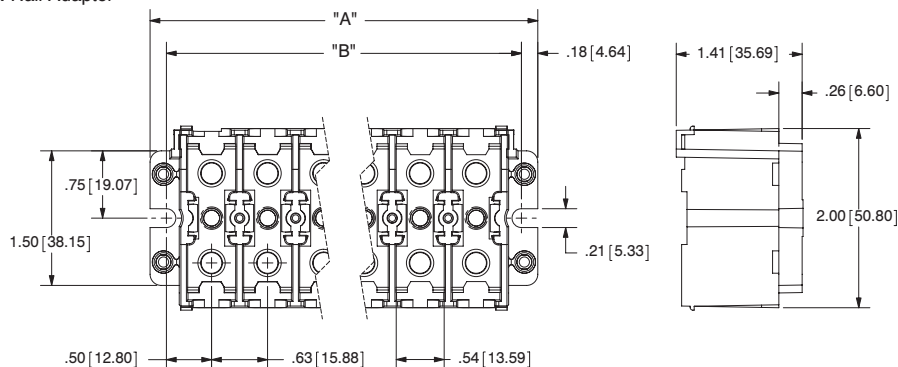

For electronic drawings or 2D/3D CAD data, send request to drawings@marathonsp.com