

N512

Inches (Millimeters)

SPECIFICATIONS

- Rating:** 5A, 600V; UL/CSA
20A, 300V; UL/CSA
- Center spacing:** .197" (5.00)
- Number of poles:** 12
- Circuits per foot:** 60
- Circuit jumper:** JN512, 12 circuits
- Wire size:** AWG #12-22 CU
- Screw size:** #4-48
- Mounting options:** C-rail,
15mm DIN rail
- Marking tape:** AT512
- Torque rating:** 12 in/lb max.
- Operating temperature:** 105°C

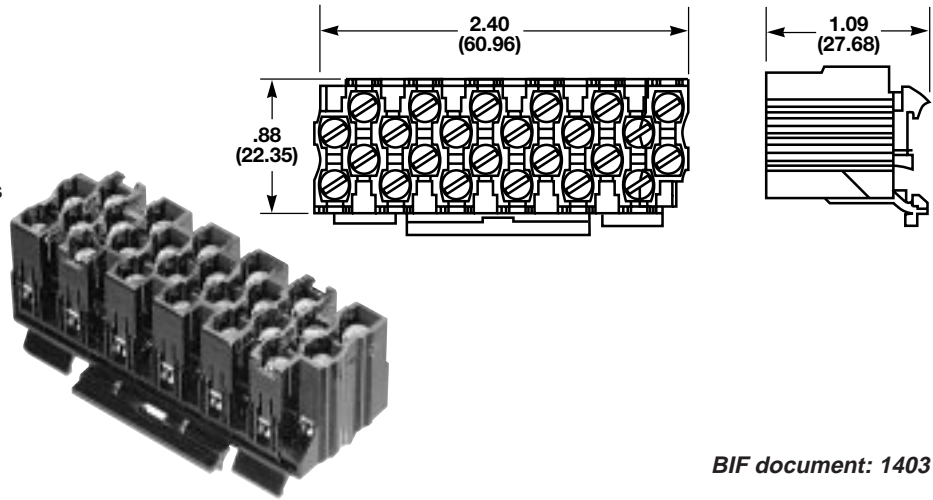

BIF document: 1403

NFT2

Inches (Millimeters)

SPECIFICATIONS

- Rating:** 40A, 600V; UL/CSA;
55A Factory Wired
- Center spacing:** .281" (7.13)
- Number of poles:** 2
- Circuits per foot:** 38
- Circuit jumper:** JN2, 2 circuits
- Wire size:** AWG #8-22 CU
- Screw size:** #8-32
- Mounting options:** C-rail
- Marking tape:** MT12-1/2
- Torque rating:** 18 in/lb max.
- Operating temperature:** 105°C

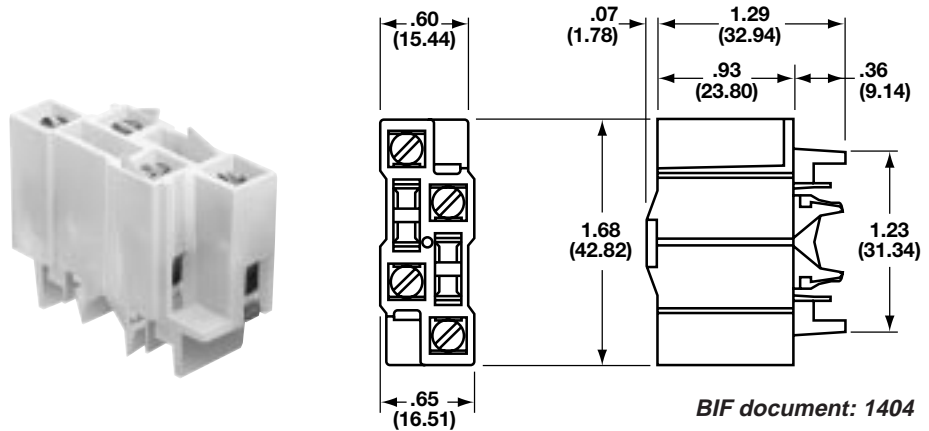

BIF document: 1404

NFT3

Inches (Millimeters)

SPECIFICATIONS

- Rating:** 40A, 600V; UL/CSA;
55A Factory Wired
- Center spacing:** .390" (9.91)
- Number of poles:** 3
- Circuits per foot:** 28
- Circuit jumper:** JN3, 2 circuits
- Wire size:** AWG #8-22 CU
- Screw size:** #8-32
- Mounting options:** C-rail
- Marking tape:** MT12-1/2
- Torque rating:** 18 in/lb max.
- Operating temperature:** 105°C

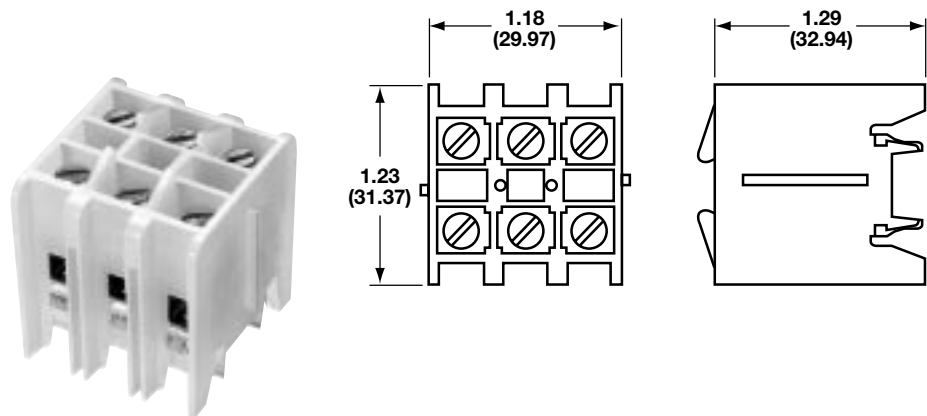

BIF document: 1405

