

EM2545 Series
Euro-Mag Terminal Blocks
Two-Tier, Stackable, 5.08 Centers

SPECIFICATIONS

Rating: 15A, 300V
 Center Spacing: .200" (5.08 mm)
 Wire Size: #12-22 AWG
 Housing Material: Green Polyamide Type 6/6, 94VO
 Contact Material: Brass Tin Plated
 Screw Size: M 3x5 Zinc Plated Steel
 Operating Temperature: 105°C (221°F) max., -40°C (-40°F) min.
 Torque Rating: 4.5 in-lb.
 Recommended PCB Hole Diameters: .055" (1.40)
 Construction: Modular design features dove-tails for interlocking to achieve longer lengths.
 Approvals: UL E62622; CSA LR701941; CE Certified

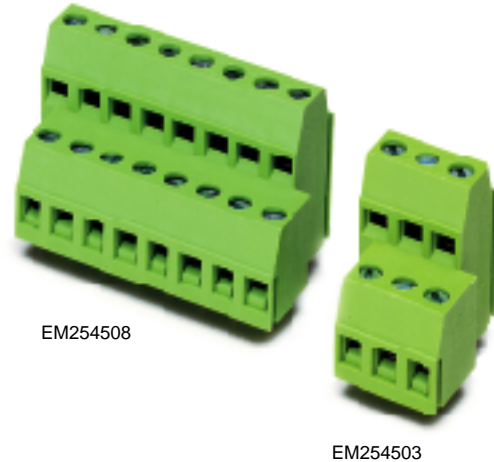

EM2545 Series

TABLE A

Position	L (mm)	Position	L (mm)
02*	10.16	14	71.12
03*	15.24	15	76.20
04	20.32	16	81.28
05	25.40	17	86.36
06	30.48	18	91.44
07	35.56	19	96.52
08*	40.64	20	101.60
09	45.72	21	106.68
10	50.80	22	111.76
11	55.88	23	116.84
12	60.96	24	121.92
13	66.04		

* Mold To Length
 To convert to inches, divide by 25.4

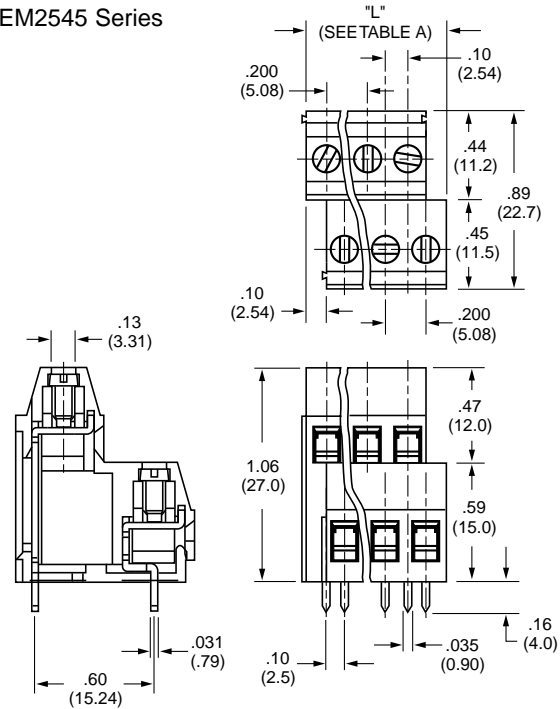

* Also available with 10.16 mm front-to-rear spacing, consult factory

Part Numbering System

Series # of Positions

EM2545 n n

02 to 24