

MAGNUM[®]

Series A1000 & Series CB1000

Single Row Terminal Blocks

SPECIFICATIONS

Rating: 15A, 250V

Center Spacing: .325" (8.26 mm)

Wire Size: #14-22 AWG CU

Screw Size: #6-32 zinc plated phillot wire-ready screws with a #2 driving recess.

Torque Rating: 9 in-lb. max.

Base: Standoffs are standard on CB1000 Series for easy flux washing.

Distance Between Barriers: .26" (6.6 mm)

Recommended PCB Hole Diameter: .070" (1.78 mm)

Operating Temperature: 105°F (221°F) max., -40°C (-40°F) min.

Molded Material: Black, UL Rated 94VO Thermoplastic

Breakdown Voltage: 1600V rms

Approvals: UL E62622; CSA LR15364; IEC Compliance; CE Certified



CB10210707

A102206

A1000 Series

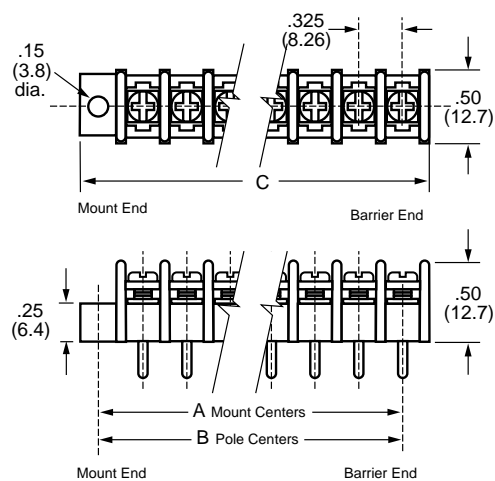

CB1000 Series

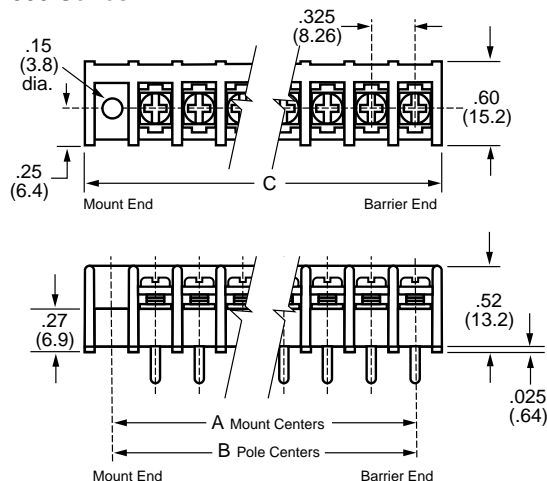

Poles	MOUNTING ENDS ONLY		BARRIER & MOUNTING ENDS B Pole Ctrs.	BARRIER ENDS ONLY C Length
	A Mount Ctrs.	C Length		
02	.98	1.37	.33	.72
03	1.30	1.69	.65	1.04
04	1.63	2.02	.98	1.37
05	1.95	2.34	1.30	1.69
06	2.28	2.67	1.63	2.02
07	2.60	2.99	1.95	2.34
08	2.93	3.32	2.28	2.67
09	3.25	3.64	2.60	2.99
10	3.58	3.97	2.93	3.32
11	3.90	4.29	3.25	3.64
12	4.23	4.62	3.58	3.97
13	4.55	4.94	3.90	4.29
14	4.88	5.27	4.23	4.62
15	5.20	5.59	4.55	4.94
16	5.53	5.92	4.88	5.27
17	5.85	6.24	5.20	5.59
18	6.18	6.57	5.53	5.92
19	6.50	6.89	5.85	6.24
20	6.83	7.22	6.18	6.57
21	7.15	7.54	6.50	6.89
22	7.48	7.87	6.83	7.22
23	7.80	8.19	7.15	7.54
24	8.13	8.52	7.48	7.87
25	8.45	8.84	7.80	8.19
26	8.78	9.17	8.13	8.52
27	9.10	9.49	8.45	8.84
28	9.43	9.82	8.78	9.17
29	9.75	10.14	9.10	9.49
30	10.08	10.47	9.43	9.82
31	10.40	10.79	9.75	10.14
32	10.73	11.12	10.08	10.47
33	11.05	11.44	10.40	10.79
34	11.38	11.77	10.73	11.12
35			11.05	11.44
36			11.38	11.77

* Dimensions in inches. To convert to millimeters, multiply by 25.4.

Part Numbering System

Series	Terminal Style	Base/End	Poles	Screw Options	Options
A1 CB1	02 03 04 07	1 2	02 to 36 02 to 34 on mount end base	Blank - std. screws 03 - stainless steel 07 - steel SEMS & washer (not available with hardware options) CA - standard captive screw 07CA - SEMS captive	AB & DR - angle mts. (A1 only-pg 6) B1 to B9 - .187" QC (all positions) EB - exit back terminals on CB1 w/07 screw option only JA, JB & JC - barrier jumpers L1 to L6 marking options (pg 23) LT1 to LT6 marking options (CB1 only-pg 23) MP & MT - mounting plates (pg 6) R26 & R45 - right angle bends (A1 only-pg 6)

Terminal Styles

Inches (Millimeters)

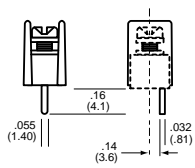

02
Circuit Board



03
Non Feed-Thru

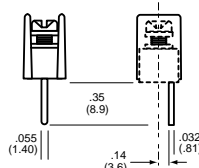

04
Wire Wrap Tail

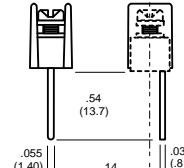

07
Extended Pin

CB1 Terminal Exit Options Tail length is .025" shorter on exit bottom terminals Inches (Millimeters)

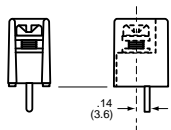

Exit Rear (std.)

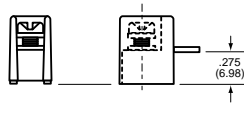

EB
Exit Back

Screw Options Wire ready screws standard on all terminal styles



Standard
Zinc Plated Steel



03
Stainless Steel



07
Steel SEMS Zinc Plated

Hardware Options (Bulk ordering part numbers are in parentheses.)

Jumpers

Quick Connects Blade Width B = .187". (For other orientations, contact factory.)

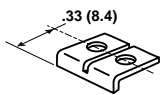

JA (JA1-XX)

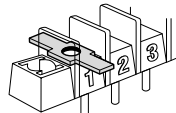

B1 (1B1) *

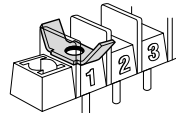

B2 (1B2) *

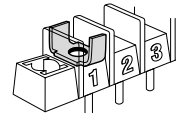

B3 (1B3) *

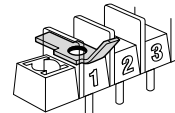

B4 (1B4) *

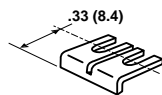

JB (JB1-XX)

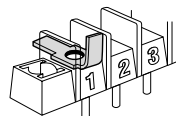

B5 (1B5) *

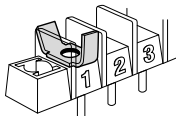

B6 (1B6) *

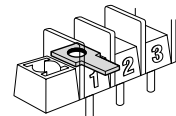

B7 (1B7)

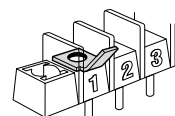

B8 (1B8)

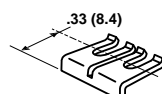

JC (JC1-XX)

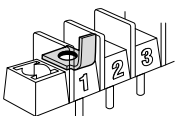

B9 (1B9)

* N/A on CB1 Series.

Continued

MAGNUM®

Series A1000 & CB1000

Single Row Terminal Blocks *Continued*

Mounting Options Inches (Millimeters)

Right Angle Bends (A1 only)

Right angle terminals are offered on the A1000 Series. Configurations are defined in these dimensions: X = pin extension beyond the block base; Z = length from block base to centerline of the terminal tip. Standard bends consist of the X and Z dimensions shown in the chart. Specify by adding the selected Bend Option Code to the terminal part no.

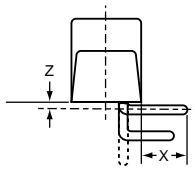

Bend Option Code	X (minimum)	Z
R26 (04 terminal only)	.14	.09
R45 (07 terminal only)	.33	.09

Dimensions in inches. To convert to millimeters, multiply by 25.4.

Angle Brackets (A1 only)

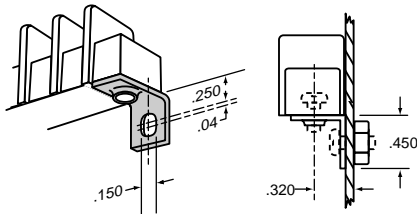

Option AB

Angle brackets enable block to be fastened at right angles to normal mount position. Bulk part no. **1AB**.

Drilled Right Angle (A1 only)

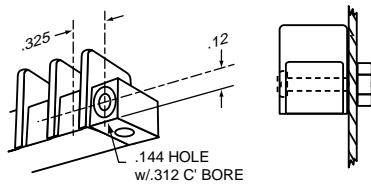

Option DR

Counterbored holes across mount ends of block enable fastening with two screws at right angles to normal mount position.

Mounting Plates

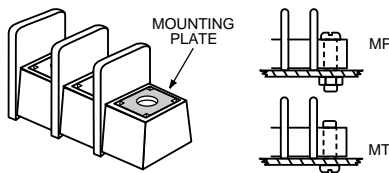

Options MP & MT

MP Metal inserts with .150" dia. hole accept #6 screw. **MT** Metal inserts with tapped hole accept #6-32 screw. Bulk Part Nos. **1MP & 1MT**.