

MAGNUM®

Series 7000

MAG-MASTER® Electronic/Field Wiring Interfaces

SPECIFICATIONS

Rating: 3 or 5A, 250V. Terminal style determines max. current, consult factory for details. Flat ribbon connectors are rated at 1 Amp per circuit.

Terminals: Field wiring terminals have bright zinc plated steel screws on .325" centers in two rows. #6-32 screws accept #14-22 AWG CU wire and .250" wide wire lugs.

Material: Black, UL Rated 94VO Thermoplastic

Operating Temperature: 105°C continuous

Approvals: UL E62622; CE Certified

Fast: Convenient connecting of field wiring to edge card, pin type, flat ribbon and sub-miniature D connectors.

Economical: No need to fabricate special adapting devices. Saves design and production time, QA/QC, field labor and reduces overall installed cost.

Versatile: Choose from six standard MAG-MASTER® interfaces offering interfaces for up to 60 circuits.

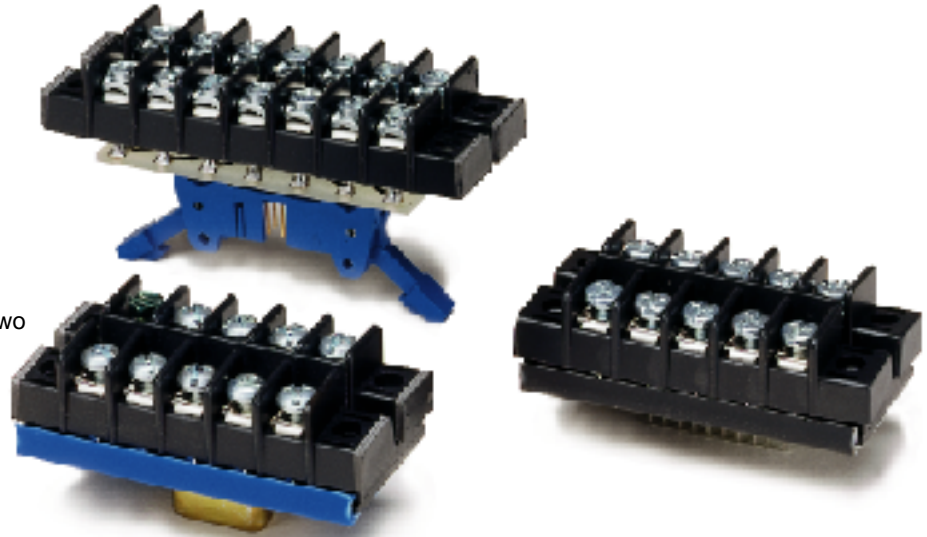

Part Numbering System

Series

n

Connector

nn

- 14 - subminiature D male
- 15 - subminiature D female
- 22 - .100 x .100 flat cable long latc
- 30 - .100 centers mass wiring header
- 32 - .156 centers mass wiring header

Circuits*

nn

- 08, 09, 10,
- 14, 15, 16,
- 20, 24, 25,
- 26, 30, 32,
- 34, 37, 40
- 50

* Circuit sizes vary by connector style.

Options

nn

- 01 - Green hex
- 07 - Steel Sems
- JA, JB & JC - Jumpers
- B7 - B9 - .187" QC
- TL - Fixed thread lock #4-40 (for connector types 14 & 15 only)

Marker strips - Contact factory
Special orientations - Contact factory

Type 14 - Subminiature D Male

Marking (if required) will identify ground screw and contacts.

Type 15 - Subminiature D Female

Marking (if required) will identify ground screw and contacts.

| Circuits | A Overall Length | B Mount Centers | C Connector Length | D Mnt. Holes To Connector | E Male | E Female |
|----------|------------------------|-----------------------|--------------------------|---------------------------------|-----------|-------------|
| 09 | 2.34 | 1.95 | 1.22 | 0.36 | 0.70 | 0.64 |
| 15 | 3.32 | 2.92 | 1.54 | 0.69 | 1.03 | 0.97 |
| 25 | 4.94 | 4.55 | 2.09 | 1.23 | 1.57 | 1.51 |
| 37 | 6.89 | 6.50 | 2.74 | 1.88 | 2.22 | 2.16 |

Dimensions in inches. To convert to millimeters, multiply by 25.4.

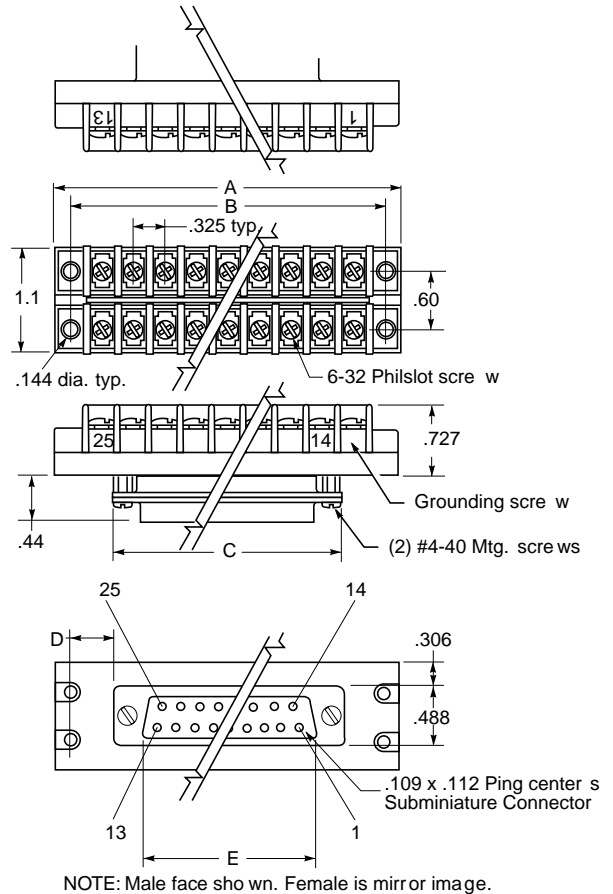

Type 22 - .100 x .100 Centers Flat Cable with Long Latch

| Circuits | A Overall Length | B Mount Centers | C Connector Length | D Mount Holes To Connector |
|----------|------------------------|-----------------------|--------------------------|----------------------------------|
| 10 | 2.34 | 1.95 | 1.26 | .345 |
| 14 | 2.99 | 2.60 | 1.46 | .570 |
| 16 | 3.31 | 2.92 | 1.55 | .682 |
| 20 | 3.96 | 3.57 | 1.76 | .908 |
| 26 | 4.94 | 4.55 | 2.05 | 1.24 |
| 34 | 6.24 | 5.85 | 2.46 | 1.69 |
| 40 | 7.21 | 6.82 | 2.76 | 2.03 |
| 50 | 8.84 | 8.45 | 3.26 | 2.59 |

Dimensions in inches. To convert to millimeters, multiply by 25.4.

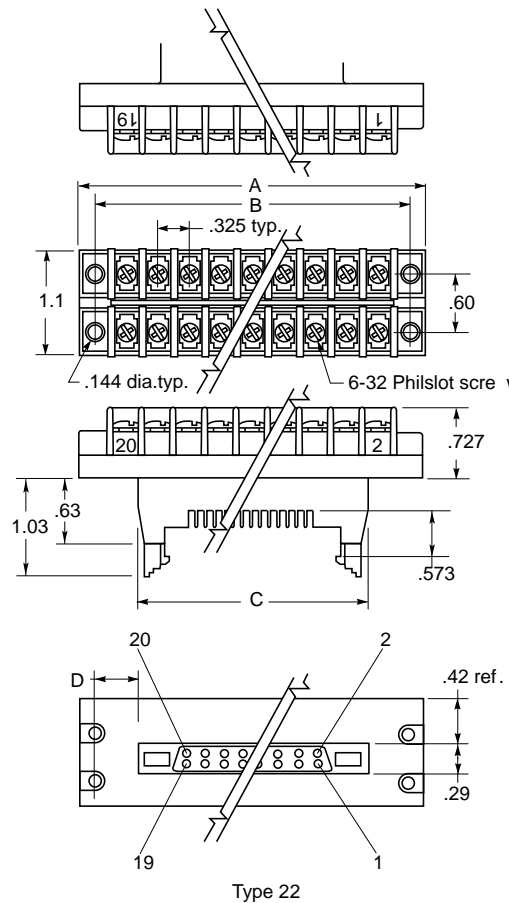

MAGNUM®

Type 30 - .100 Centers Mass Wiring Headers

| Circuits | A Overall Length | B Mount Centers | C Connector Length | D Mount Holes To Connector |
|----------|------------------------|-----------------------|--------------------------|----------------------------------|
| 08 | 2.02 | 1.62 | 0.80 | 0.41 |
| 10 | 2.34 | 1.95 | 1.00 | 0.48 |
| 16 | 3.32 | 2.92 | 1.60 | 0.66 |
| 20 | 3.97 | 3.57 | 2.00 | 0.79 |
| 24 | 4.62 | 4.22 | 2.40 | 0.91 |
| 30 | 5.59 | 5.20 | 3.00 | 1.10 |

Dimensions in inches. To convert to millimeters, multiply by 25.4.

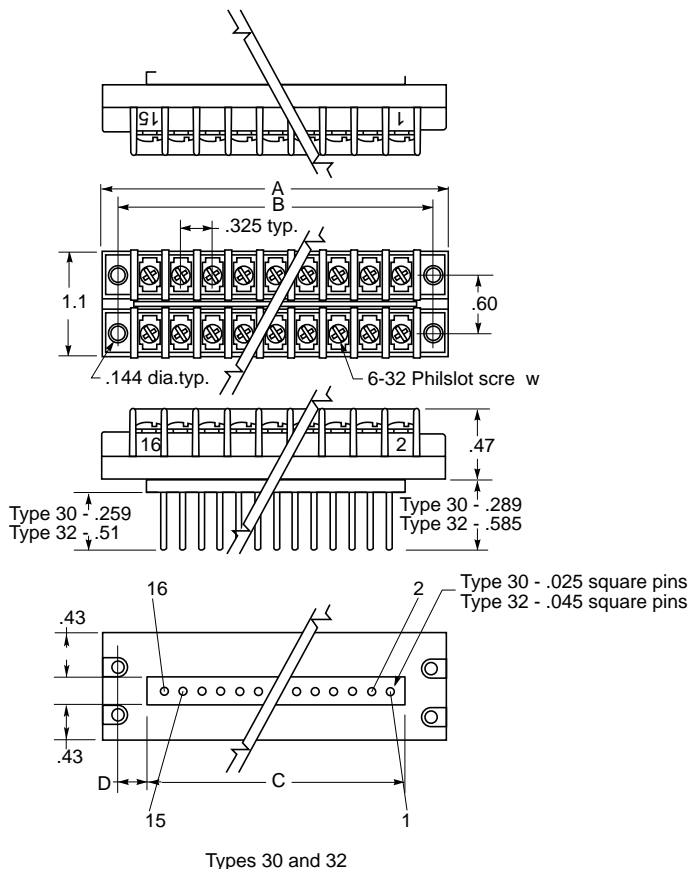

Type 32 - .156 Centers Mass Wiring Headers

| Circuits | A Overall Length | B Mount Centers | C Connector Length | D Mount Holes To Connector |
|----------|------------------------|-----------------------|--------------------------|----------------------------------|
| 16 | 3.32 | 2.92 | 2.50 | 0.21 |
| 24 | 4.62 | 4.22 | 3.74 | 0.24 |
| 32 | 5.92 | 5.52 | 4.99 | 0.27 |
| 40 | 7.22 | 6.82 | 6.24 | 0.29 |

Dimensions in inches. To convert to millimeters, multiply by 25.4.

Series 7000 MAG-MASTER® Continued

Screw Options



03
Stainless Steel



07
Steel SEMS
Zinc Plated

Hardware Options (Bulk ordering part numbers are in parentheses.)

Jumpers

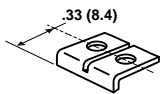

JA (JA1-XX)

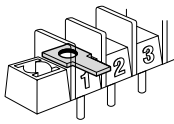

B7 (1B7)

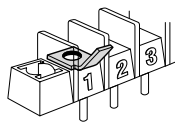

B8 (1B8)

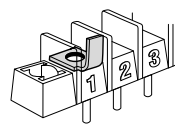

B9 (1B9)

Quick Connects Blade Width B = .187".
(For other orientations, contact factory.)

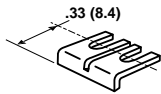

JB (JB1-XX)

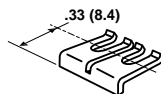

JC (JC1-XX)

Marker Strips

Optional Marker Strips are available for MAG-MASTER® in the two styles of marking shown here. The strips install with the mounting screws under the terminal block extending beyond the sides of the block. Shipped in pairs, unassembled.

To order, specify MS followed by MAG-MASTER® part no. and style desired. Example: MS722120-1. If special markings are required, submit a drawing.

DO NOT ADD STYLE NO. FOR MARKER STRIPS USED WITH TYPE 14 AND TYPE 15 (D-SUBMINIATURE CONNECTORS). MARKING WILL CORRESPOND TO CONTACT NUMBERS ON CONNECTOR.



Style 1

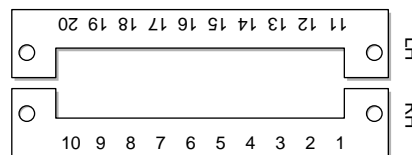

Style 2