

**30.22**

- Sub miniature relay
- Low level switching capability
- Sensitive DC coil, 200mW
- Wash tight: RT III

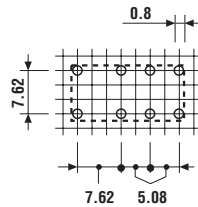

- Low consumption
- P.C.B. mounting

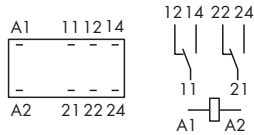
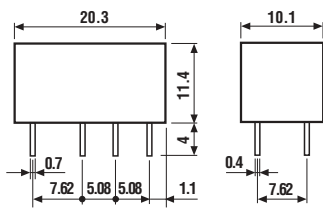

Copper side view

\* For 250 V applications, where requirements for pollution degree 1 are met.

<b>Contact specifications</b>		
Contact configuration		2 CO (DPDT)
Rated current/Maximum peak current	A	2/3
Rated voltage/Maximum switching voltage	V AC	125/250*
Rated load in AC1	VA	125
Rated load in AC15 (230 V AC)	VA	25
Single phase motor rating (230 V AC)	kW	—
Breaking capacity in DC1: 30/110/220 V	A	2/0.3/—
Minimum switching load	mW (V/mA)	10 (0.1/1)
Standard contact material		AgNi + Au
<b>Coil specifications</b>		
Nominal voltage (U <sub>N</sub> )	V AC (50/60 Hz)	—
	V DC	5 - 6 - 9 - 12 - 24 - 48
Rated power AC/DC	VA (50 Hz)/W	—/0.2
Operating range	AC	—
	DC	see table page 5
Holding voltage	AC/DC	—/0.35 U <sub>N</sub>
Must drop-out voltage	AC/DC	—/0.05 U <sub>N</sub>
<b>Technical data</b>		
Mechanical life AC/DC	cycles	—/10 · 10 <sup>6</sup>
Electrical life at rated load AC1	cycles	100 · 10 <sup>3</sup>
Operate/release time	ms	6/2
Insulation according to EN 61810-1 ed. 2		1.2 kV/2
Insulation between coil and contacts (1.2/50 μs)	kV	1.5
Dielectric strength between open contacts	V AC	750
Ambient temperature range	°C	-40...+85
Environmental protection		RT III
<b>Approvals (according to type):</b>		
		GOST

**ORDERING INFORMATION**

Example: a 30 series P.C.B. relay with 2 CO (DPDT) contacts, with coil rated at 12 V sensitive DC.

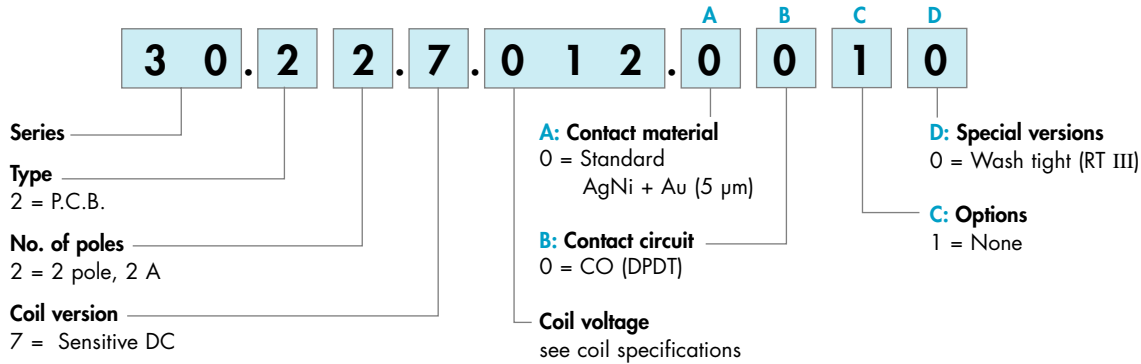

**TECHNICAL DATA**

**INSULATION**

Insulation according to EN 61810-1 ed. 2	insulation rated voltage	V	125
	rated impulse withstand voltage	kV	1.2
	pollution degree		2
	overvoltage category		I
Dielectric strength between adjacent contacts	V AC		1,500

**OTHER DATA**

Bounce time: NO/NC	ms	1/3	
Vibration resistance (10...55)Hz, max. ± 1 mm: NO/NC	g/g	10/10	
Power lost to the environment	without contact current	W	0.2
	with rated current	W	0.4
Recommended distance between relays mounted on P.C.B.s	mm	≥ 5	

**CONTACT SPECIFICATIONS**

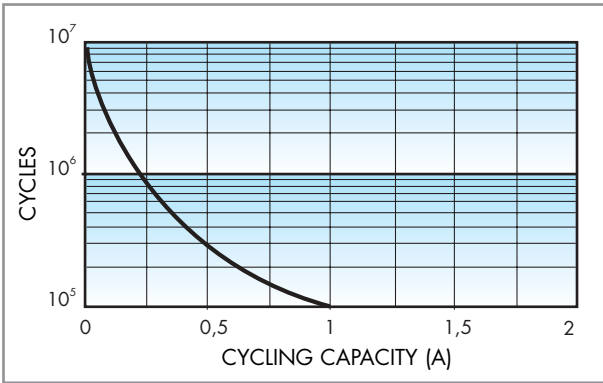

Cycling capacity.  
Note: the rated current of 2 A coincides with the limiting continuous current.

**COIL SPECIFICATIONS**

**DC VERSION DATA (0.2 W sensitive)**

Nominal voltage $U_N$	Coil code	Operating range		Resistance consumption R	Rated coil consumption I at $U_N$
		$U_{min}$	$U_{max}$		
V		V	V	$\Omega$	mA
5	7.005	3.7	7.5	125	40
6	7.006	4.5	9	180	33
9	7.009	6.7	13.5	405	22
12	7.012	8.4	18	720	16
24	7.024	16.8	36	2,880	8.3
48	7.048	36	72	11,520	4.1

**R 30 DC**

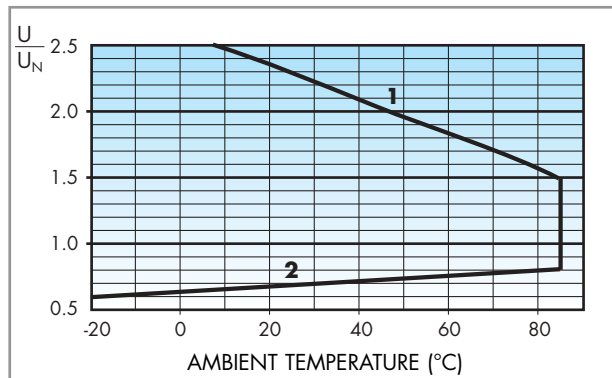

Operating range vs ambient temperature.  
1 - Max coil voltage permitted.  
2 - Min pick-up voltage with coil at ambient temperature.