

DC Fans

Model 298

Size: 120 mm x 25 mm (4.72" x 1")

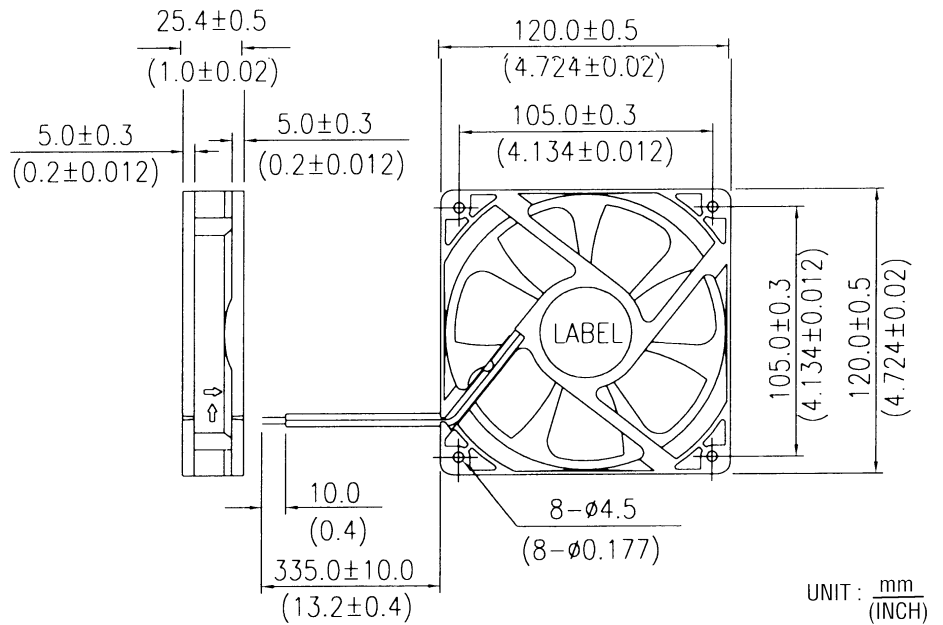

Part Number	Bearings	Voltage	Voltage Range	Current(mA)	Input(watts)	Noise(dBA)	Speed(rpm)	Airflow(cfm)	Air Pressure (In H2O)
298DS-1LP11-000	Ball	12	7.0-13.8	450	7.32	42.5	2800	95.3	0.22
298DS-2LP11-000	Ball	24	14.0-27.6	260	6.24	42.5	2800	95.3	0.22
298DH-1LP11-000	Ball	12	7.0-13.8	130	4.32	37.5	2470	86.5	0.19
298DH-2LP11-000	Ball	24	14.0-27.6	200	4.80	37.5	2470	86.5	0.19
298DM-1LP11-000	Ball	12	7.0-13.8	200	2.40	34	2100	72.4	0.13
298DM-2LP11-000	Ball	24	14.0-27.6	140	3.36	34	2100	72.4	0.13
298DL-1LP11-000	Ball	12	7.0-13.8	140	1.68	30	1750	61.8	0.10
298DL-2LP11-000	Ball	24	14.0-27.6	100	2.40	30	1750	61.8	0.10

Optional frequency generator or rotation detector versions available. Consult factory.

298DL/DM Performance Curve

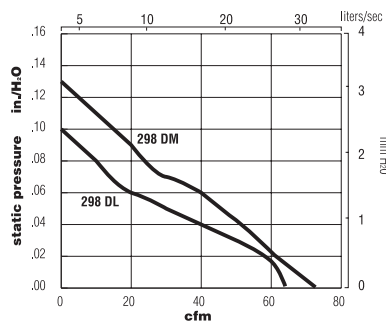

298DS/DH Performance Curve

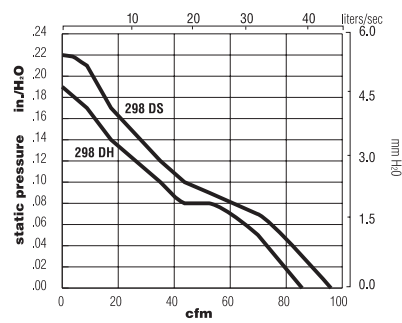

ETRI Model 298 DC FANS

Size: 120 mm x 25 mm (4.72" x 1")



ELECTRICAL SPECIFICATIONS

Item	Specification	Conditions/Tolerances
Motor type	DC	brushless
Input current	at nominal voltage	±10%
Input power	at nominal voltage	±10%
Max air flow / Back pressure	All tested in submerged orifice chamber	±4% cfm/±8% pressure
Dielectric strength	5 mA leakage @ 500 VAC, 60 Hz.	1 minute between frame and (+) terminal
Electrical connection	UL 1007 awg 24	305 mm (12"), (+) red (-) black
Speed	at nominal voltage	±4%

MECHANICAL SPECIFICATIONS

Item	Specification	Conditions/Tolerances
Life expectancy	50,000 hours	continuous operation @ 25°C, 65% relative humidity
Bearing	ball bearing	top and bottom
Airflow direction	air intake over impeller	
Housing material	PBT plastic - 30% glass fiber	UL 94V-0
Mounting type	flange	
Impeller	PBT plastic - 20% glass fiber	UL 94V-0
Weight	.18 kg (6.35 oz.)	
Rotation	clockwise viewed from nameplate	

ENVIRONMENTAL SPECIFICATIONS

Item	Specification	Conditions/Tolerances
Operating temperature	- 10 to + 70°C	
Storage temperature	- 40 to + 75°C	
Drop test	one drop ea. 3 faces	30 cm height onto 10 mm thick wooden board
Shock test	50 g peak acceleration	duration - 11 ms
Vibration test	x,y,z direction, 1 hour	frequency - 10-55-10 Hz, amplitude - 0.75 mm
Acoustical	anechoic chamber at free air	microphone - 1 meter away

PROTECTION

Item	Specification	Conditions/Tolerances
Locked rotor	impedance protected	72 hours @ rated voltage
Polarity protected	will withstand pos and neg lead reversal	
Insulation class	UL class A	
Auto restart	automatic restart by timer	locked rotor condition
Agency approvals	UL, CSA, VDE, CE	
Warranty	3 years	

PANEL CUT-OUT

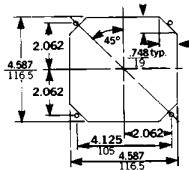

ACCESSORIES

ETRI fans are available with a wide range of accessories, from finger guards to filter assemblies to special termination. Request our accessories brochure or call your nearest distributor for complete details.



1503, Rocky River Road North
 Monroe, NC 28110 USA
 Tel: 704.289.5423
 Fax: 704.283.7170

9-11, rue de Moulin des Bruyères
 92400 Courbevoie FRANCE
 Tel: (33-1) 49 04 92 00
 Fax: (33-1) 47 89 09 38

Website: <http://www.etrinet.com> Email: sales@etrinet.com

