

THE INFORMATION CONTAINED IN THIS DRAWING IS THE SOLE PROPERTY OF ANDERSON POWER PRODUCTS. ANY REPRODUCTION IN PART OR WHOLE WITHOUT THE WRITTEN PERMISSION OF ANDERSON POWER PRODUCTS IS PROHIBITED.

ANDERSON POWER PRODUCTS RESERVES THE RIGHT TO ALTER PRODUCT TYPES, THEIR TECHNICAL DATA, DIMENSION, STYLE AND ACCESSORIES WITHOUT PRIOR NOTIFICATION.

DATE	5/25/06
BY:	AF
DESCRIPTION OF CHANGES	ECRN 14018; ADD 75LOKRED
REV.	1

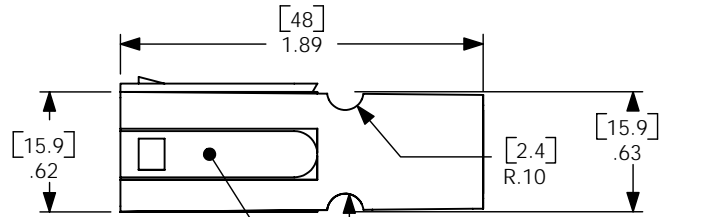

DOVETAILS ALLOW STACKING IN VERTICAL, HORIZONTAL, OR IN BLOCK CONFIGURATIONS.

WHEN MATED SIDE TO SIDE, HALF-ROUNDS ALIGN TO FORM A SLOT FOR ROLL PIN INSERTION (OPTIONAL).

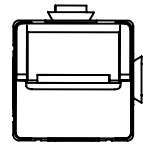
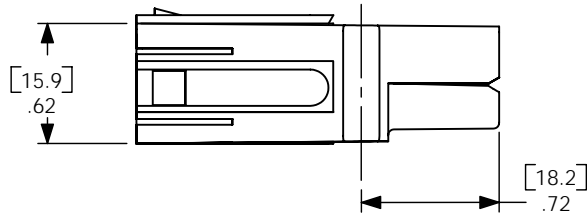

MATED PAIR OF HOUSINGS

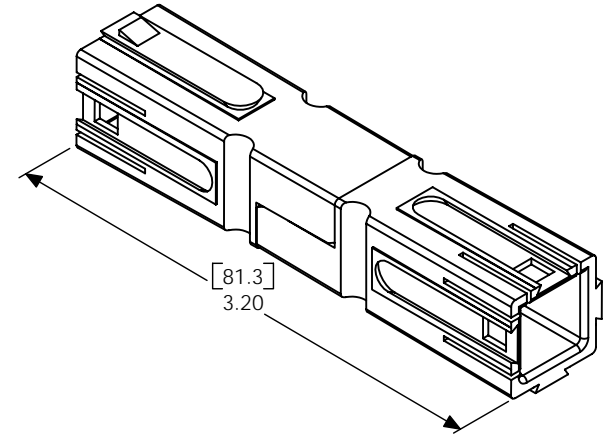

45° HOOD

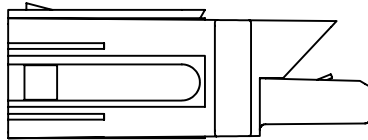

90° NO HOOD

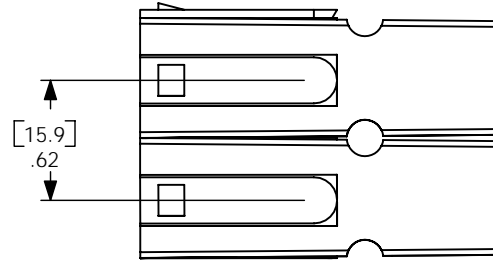
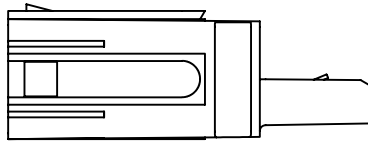

CAT. NO	COLOR	HOOD
75LOKBLU	BLUE	STANDARD
75LOKBLK	BLACK	STANDARD
75LOKWHT	WHITE	STANDARD
75LOKGRN	GREEN	STANDARD
75LOKRED	RED	STANDARD
75LOK90BLU	BLUE	90 DEG
75LOK90BLK	BLACK	90 DEG
75LOK90WHT	WHITE	90 DEG
75LOK90GRN	GREEN	90 DEG
75LOK90RED	RED	90 DEG
75LOK45BLU	BLUE	45 DEG
75LOK45BLK	BLACK	45 DEG
75LOK45WHT	WHITE	45 DEG
75LOK45GRN	GREEN	45 DEG
75LOK45RED	RED	45 DEG

NOTES:

1. SPRING/HOUSING ASSEMBLIES ARE UL RECOGNIZED PER FILE E26226 AND CSA CERTIFIED PER LR25154.
2. THESE HOUSING ASSEMBLIES ACCOMMODATE ANDERSON CONTACTS FOR WIRE RANGES FROM #12 AWG TO #6 AWG.
3. FOR ASSEMBLY INSTRUCTIONS, SEE DOCUMENT 1S1072.
4. HOUSINGS: POLYCARBONATE, UL94V0.
SPRING: STAINLESS STEEL
FOR OTHER COLORS, CONSULT ANDERSON POWER PRODUCTS

ITEM NO.	PART OR IDENTIFYING NO.	NOMENCLATURE OR DESCRIPTION	MATERIAL SPECIFICATION	QTY RECD
COPYRIGHT 2001 ANDERSON POWER PRODUCTS. ALL RIGHTS RESERVED. UNAUTHORIZED REPRODUCTION HEREBY PROHIBITED.				
DIMENSIONS ARE IN INCHES DIMENSIONS IN PARENTHESES [] ARE IN MILLIMETERS		CAD GENERATED DRAWING, DO NOT MANUALLY UPDATE		ANDERSON POWER PRODUCTS PP75 LOCKING HOUSINGS SPECIFICATION: 114321S1
TOLERANCES ARE: 2PL- ±.02 [±.5]		APPROVALS	DATE	
MATERIALS: SEE NOTES		DRAWN	CMS 5/18/01	
FINISH AS MOLDED		CHECKED	DJD 5/23/01	
DO NOT SCALE DRAWING		RESP ENG	UFN 5/25/01	SIZE A
		MFG ENG	CHB 5/25/01	SCALE NONE
		QUAL ENG	RPO 5/23/01	CADFILES/01443
			SHEET 1 OF 1	REV. 1