

THE INFORMATION CONTAINED IN THIS DRAWING IS THE SOLE PROPERTY OF ANDERSON POWER PRODUCTS. ANY REPRODUCTION IN PART OR WHOLE WITHOUT THE WRITTEN PERMISSION OF ANDERSON POWER PRODUCTS IS PROHIBITED.

COMPONENTS FOR SBE160/SBX175
MANUAL RELEASE
CHARGER/TRUCK HALF

COMPONENT	QTY
CHARGER/TRUCK BRACKET ASSY	1
SCREWS	2
WASHERS	2
NUTS	2

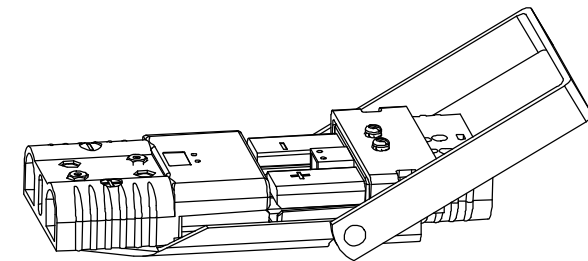
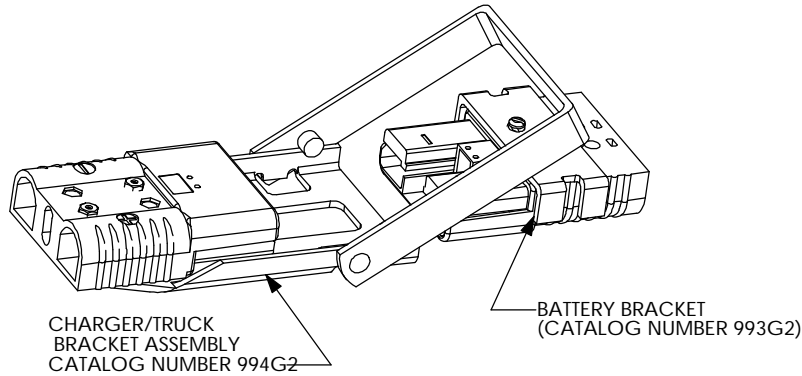

OPEN POSITION

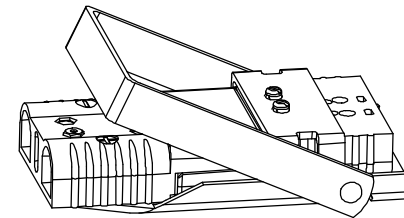

CLOSED POSITION

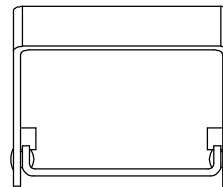
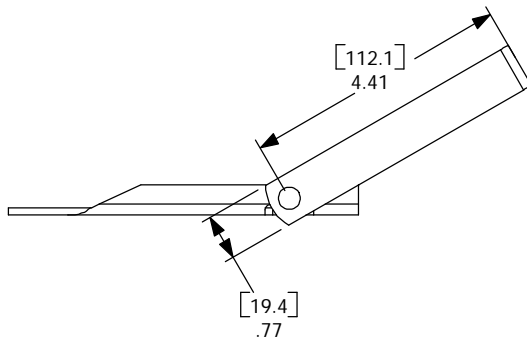
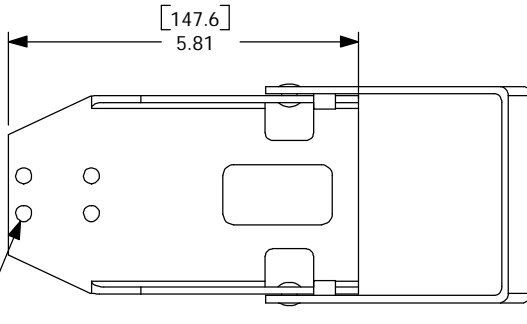

DATE	
BY:	
DESCRIPTION OF CHANGES	
REV.	

- NOTES:
- MATERIALS:
PLATE AND HANDLE- #11 GA COLD ROLLED STEEL.
FINISH WITH ELECTROSTATIC POWDER COAT EPOXY-CRIMSON
 - USE WITH CATALOG NUMBER 993G2 (BATTERY BRACKET)
 - CONNECTOR SOLD SEPARATELY

ITEM NO.	PART OR IDENTIFYING NO.	NOMENCLATURE OR DESCRIPTION	MATERIAL SPECIFICATION	QTY REQD
COPYRIGHT 2000 ANDERSON POWER PRODUCTS. ALL RIGHTS RESERVED. UNAUTHORIZED REPRODUCTION HEREBY PROHIBITED.				
DIMENSIONS ARE IN INCHES DIMENSIONS IN PARENTHESES [] ARE IN MILLIMETERS		CAD GENERATED DRAWING. DO NOT MANUALLY UPDATE	ANDERSON POWER PRODUCTS	
TOLERANCES ARE: 2PL- ±.02 [±.5]		APPROVALS	DATE	
MATERIALS: SEE NOTES		DRAWN	CMS 4/20/00	
FINISH SEE NOTES		CHECKED	DJD 4/24/00	
NEXT ASSY USED ON		RESP ENG	UFN 4/24/00	
APPLICATION		MFG ENG	CHB 5/8/00	
DO NOT SCALE DRAWING		QUAL ENG	RPO 5/8/00	
SCALE NONE			SIZE A	REV. 0
CADFILES/01213			SPECIFICATION: 114239S2	
			SHEET 1 OF 1	