

THE INFORMATION CONTAINED IN THIS DRAWING IS THE SOLE PROPERTY OF ANDERSON POWER PRODUCTS. ANY REPRODUCTION IN PART OR WHOLE WITHOUT THE WRITTEN PERMISSION OF ANDERSON POWER PRODUCTS IS PROHIBITED.

DATE	7/9/04
BY:	CMS
DESCRIPTION OF CHANGES	ECRN 13717
REV.	1

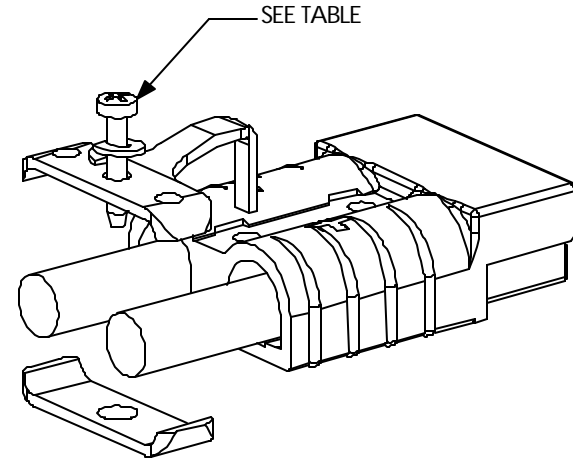
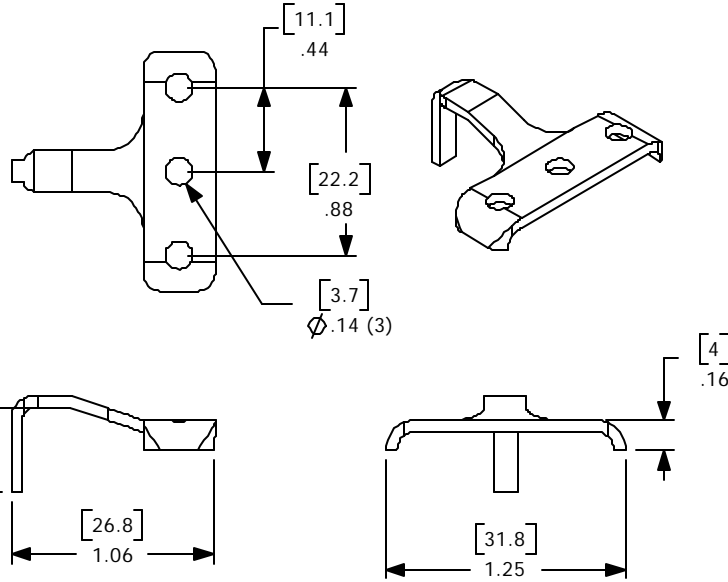

MOUNTING OF CABLE CLAMP

CAT. NO.	SCREW LENGTH	
	IN	MM
990	3/4"	19
990G2	5/8"	15.9

NOTES:

1. MATERIAL: COLD ROLLED STEEL, ZINC YELLOW FINISH
2. HARWARE KIT INCLUDES ONE SELF-TAPPING SCREW AND ONE LOCK WASHER
3. USE WITH TWO #6-8 OR #10-12 SINGLE CONDUCTOR CABLES

ITEM NO.	PART OR IDENTIFYING NO.	NOMENCLATURE OR DESCRIPTION	MATERIAL SPECIFICATION	QTY. REQD.
----------	-------------------------	-----------------------------	------------------------	------------

COPYRIGHT 2000 ANDERSON POWER PRODUCTS. ALL RIGHTS RESERVED. UNAUTHORIZED REPRODUCTION HEREBY PROHIBITED.

DIMENSIONS ARE IN INCHES DIMENSIONS IN PARENTHESES [] ARE IN MILLIMETERS		CAD GENERATED DRAWING, DO NOT MANUALLY UPDATE		ANDERSON POWER PRODUCTS	
TOLERANCES ARE: 2PL- ±.02 [±.5]		APPROVALS	DATE		
MATERIALS:		DRAWN	CMS	1/25/00	
SEE NOTES		CHECKED	DJD	1/28/00	
FINISH		RESP ENG	UFN	2/7/00	
SEE NOTES		MFG ENG	CHB	2/8/00	
DO NOT SCALE DRAWING		QUAL ENG	RPO	2/8/00	
SIZE	A	SPECIFICATION:		114224S1	
SCALE	NONE	CADFILES/01175		REV.	1
SHEET 1 OF 1					

NEXT ASSY	USED ON
APPLICATION	

