

THE INFORMATION CONTAINED IN THIS DRAWING IS THE SOLE PROPERTY OF ANDERSON POWER PRODUCTS. ANY REPRODUCTION IN PART OR WHOLE WITHOUT THE WRITTEN PERMISSION OF ANDERSON POWER PRODUCTS IS PROHIBITED.

CUT-AWAY VIEW SHOWING HOW TO EXTRACT A CONTACT

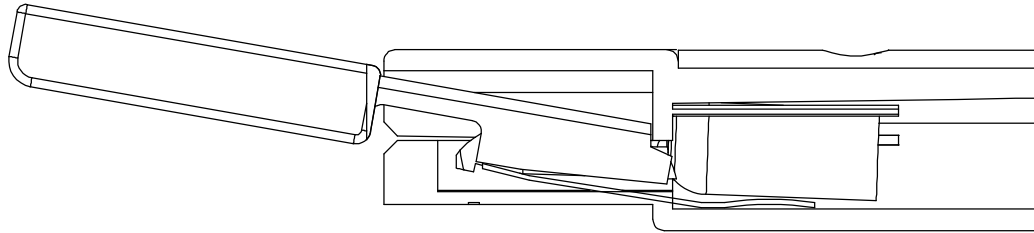

SLIDE TOOL INTO THE MATING END OF THE CONNECTOR, ALONGSIDE THE RIGHT SIDE OF THE CONTACT. PUSH THE TOOL IN UNTIL THE FRONT END IS UNDER THE BARRIER WALL. PUT DOWNWARD PRESSURE ON THE HANDLE, COMpressING THE SPRING. WHILE THE SPRING IS COMPRESSED, PULL ON THE CABLE TO EXTRACT THE CONTACT.

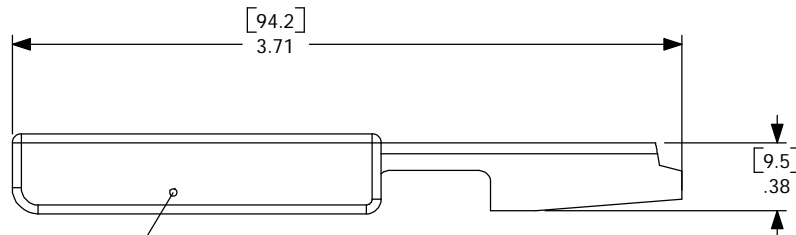
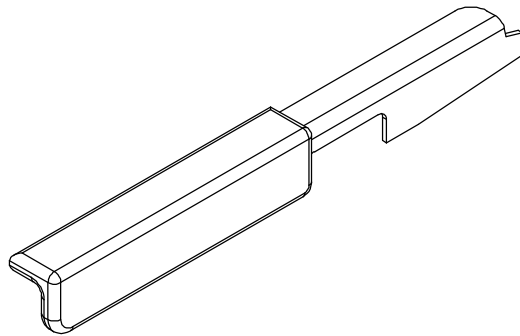

VINYL COATED HANDLE

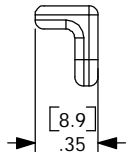

NOTES:  
 MATERIAL:  
 #22 (.03") GA. COLD ROLLED LOW CARBON STEEL  
 KANIGEN PLATE .0003/.0005 THK  
 HANDLE COATING- RED VINYL

ITEM NO.	PART OR IDENTIFYING NO.	NOMENCLATURE OR DESCRIPTION	MATERIAL SPECIFICATION	QTY REQD
COPYRIGHT 2000 ANDERSON POWER PRODUCTS. ALL RIGHTS RESERVED. UNAUTHORIZED REPRODUCTION HEREBY PROHIBITED.				
DIMENSIONS ARE IN INCHES DIMENSIONS IN PARENTHESES [ ] ARE IN MILLIMETERS		CAD GENERATED DRAWING. DO NOT MANUALLY UPDATE		
TOLERANCES ARE: 2PL- ±.02 [±.5]		APPROVALS DATE		
MATERIALS: SEE NOTES		DRAWN CMS 4/25/00		
FINISH SEE NOTES		CHECKED DJD 5/5/00		
NEXT ASSY USED ON		RESP ENG UFN 5/15/00		
APPLICATION		MFG ENG CHB 5/8/00		
DO NOT SCALE DRAWING		QUAL ENG RPO 5/8/00		
		ANDERSON POWER PRODUCTS		
		CATALOG NUMBER 969P1 SBE160/SBX175 EXTRACTION TOOL WITH INSULATED HANDLE		
		SIZE	SPECIFICATION:	REV.
		A	114244S1	0
		SCALE	CADFILES/01216	SHEET 1 OF 1
		NONE		

DATE	
BY:	
DESCRIPTION OF CHANGES	
REV.	