

THE INFORMATION CONTAINED IN THIS DRAWING IS THE SOLE PROPERTY OF ANDERSON POWER PRODUCTS. ANY REPRODUCTION IN PART OR WHOLE WITHOUT THE WRITTEN PERMISSION OF ANDERSON POWER PRODUCTS IS PROHIBITED.

DATE	6/11/07
BY:	CMS
DESCRIPTION OF CHANGES	ECRN 14168-1.63 WAS 1.51...23 WAS .14
REV	1

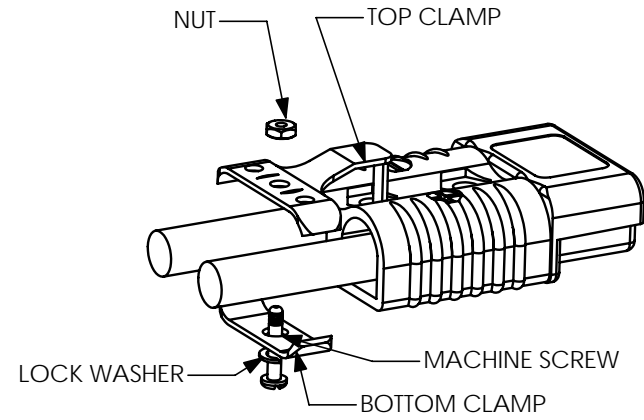
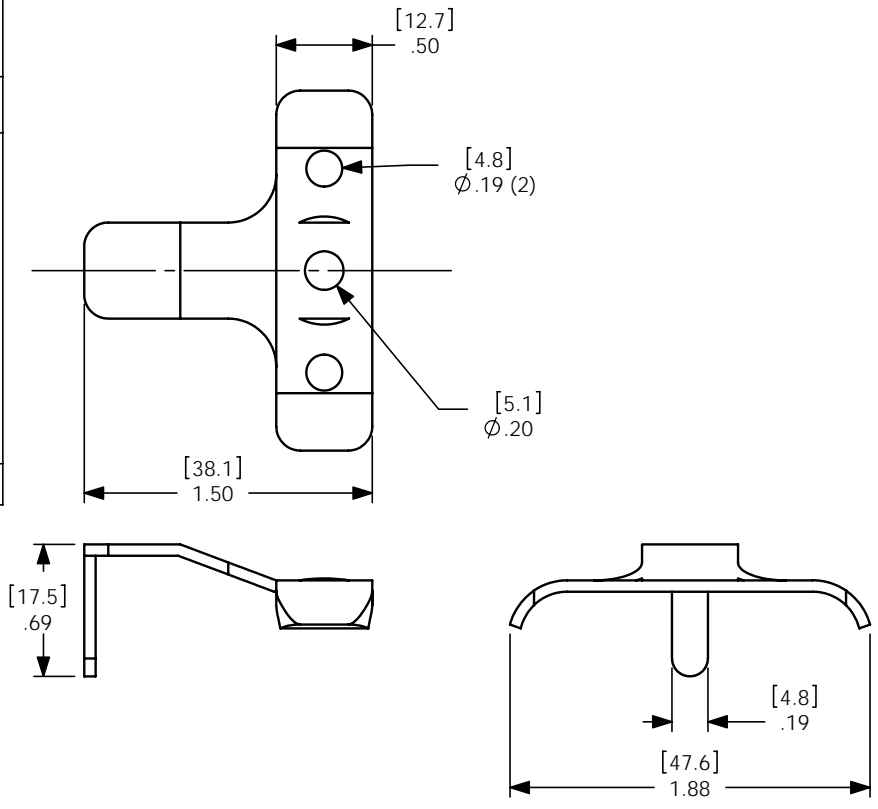

NOTES:

1. MATERIAL- COLD ROLLED STEEL; ZINC PLATE- YELLOW
2. HARDWARE KIT INCLUDES- ONE MACHINE SCREW, ONE NUT ONE LOCK WASHER
3. CONNECTOR SOLD SEPARATELY

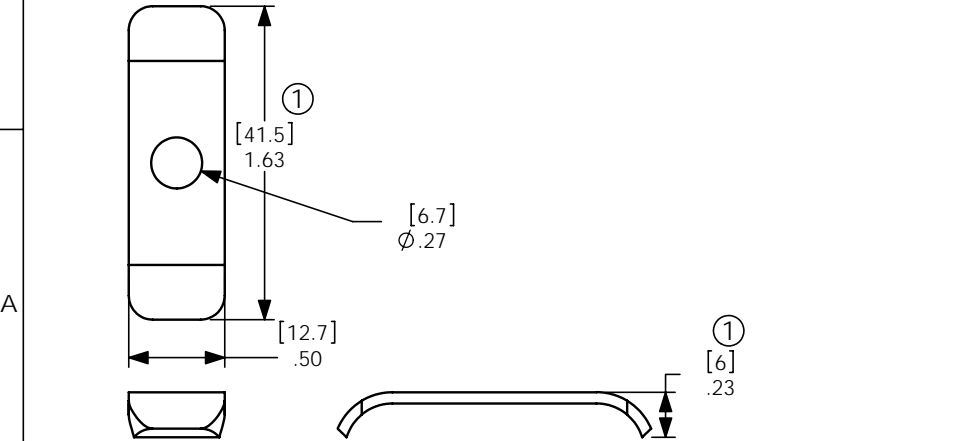

ITEM NO.	PART OR IDENTIFYING NO.	NOMENCLATURE OR DESCRIPTION	MATERIAL SPECIFICATION	QTY RECD
COPYRIGHT 2000 ANDERSON POWER PRODUCTS. ALL RIGHTS RESERVED. UNAUTHORIZED REPRODUCTION HEREBY PROHIBITED.				
DIMENSIONS ARE IN INCHES DIMENSIONS IN PARENTHESES [] ARE IN MILLIMETERS		CAD GENERATED DRAWING, DO NOT MANUALLY UPDATE		
TOLERANCES ARE: 2PL- \pm .02 [\pm .5]		APPROVALS DATE		
MATERIALS: SEE NOTES		DRAWN CMS 2/7/00		
FINISH SEE NOTES		CHECKED DJD 2/8/00		
DO NOT SCALE DRAWING		RESP ENG UFN 2/8/00		
		MFG ENG CHB 2/9/00		
		QUAL ENG RPO 2/10/00		
		SIZE SPECIFICATION: A 114228S1		REV. 1
		SCALE NONE	CADFILES/01186	SHEET 1 OF 1

ANDERSON POWER PRODUCTS

CATALOG NUMBER 945
SB175 CABLE CLAMP FOR
SINGLE CONDUCTOR CABLE
#4 AWG TO 1/0