

THE INFORMATION CONTAINED IN THIS DRAWING IS THE SOLE PROPERTY OF ANDERSON POWER PRODUCTS. ANY REPRODUCTION IN PART OR WHOLE WITHOUT THE WRITTEN PERMISSION OF ANDERSON POWER PRODUCTS IS PROHIBITED.

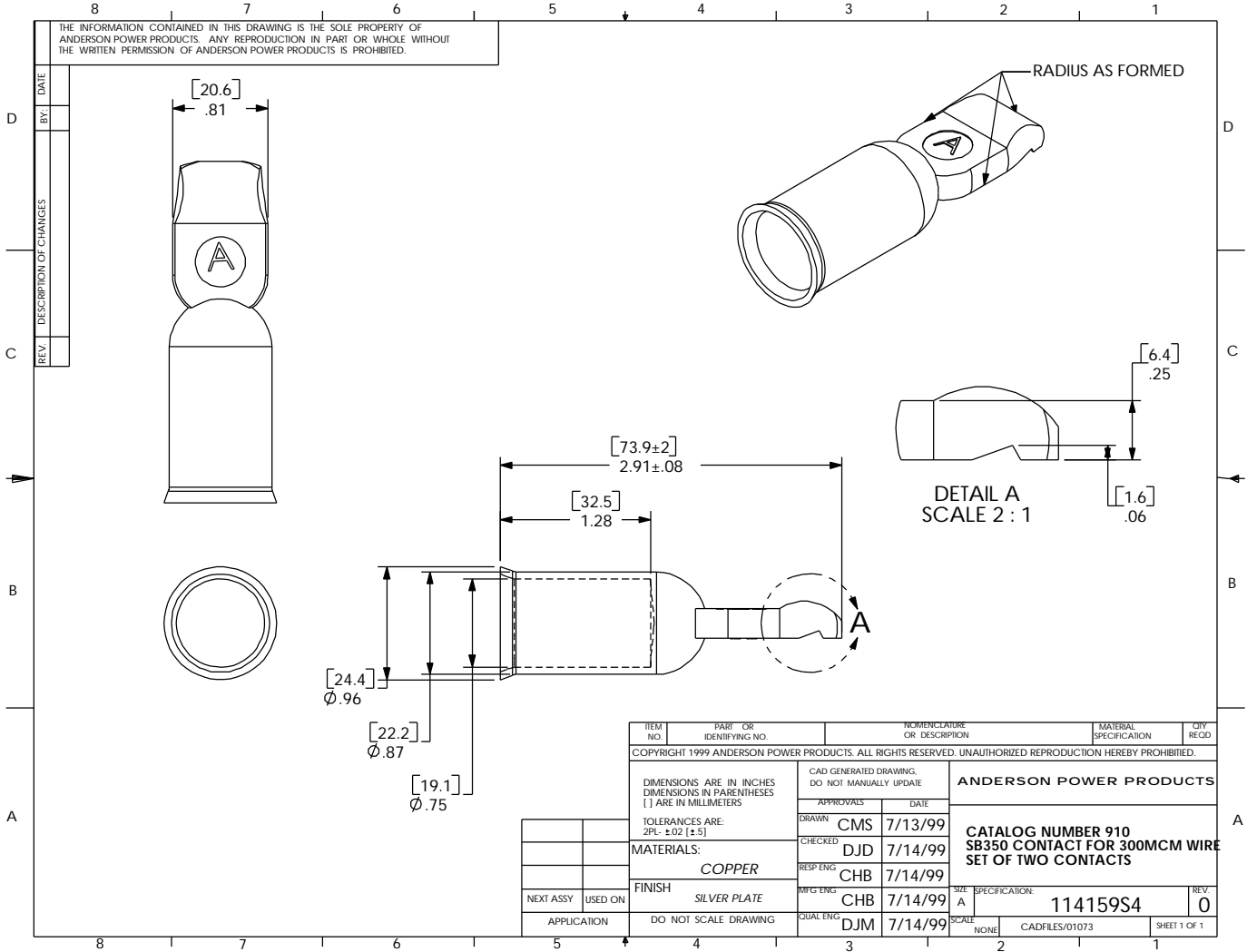

REV.	DESCRIPTION OF CHANGES	BY:	DATE

NEXT ASSY	USED ON
APPLICATION	DO NOT SCALE DRAWING

ITEM NO.	PART OR IDENTIFYING NO.	NOMENCLATURE OR DESCRIPTION	MATERIAL SPECIFICATION	QTY RECD
COPYRIGHT 1999 ANDERSON POWER PRODUCTS. ALL RIGHTS RESERVED. UNAUTHORIZED REPRODUCTION HEREBY PROHIBITED.				
DIMENSIONS ARE IN INCHES DIMENSIONS IN PARENTHESES [ ] ARE IN MILLIMETERS		CAD GENERATED DRAWING. DO NOT MANUALLY UPDATE		
TOLERANCES ARE: 2PL ±.02 [±.5]		ANDERSON POWER PRODUCTS		
MATERIALS: <i>COPPER</i>		CATALOG NUMBER 910 SB350 CONTACT FOR 300MCM WIRE SET OF TWO CONTACTS		
FINISH SILVER PLATE		SIZE A SPECIFICATION: 114159S4		
APPLICATION		SCALE: NONE CADFILES/01073 SHEET 1 OF 1		

APPROVALS	DATE
DRAWN CMS	7/13/99
CHECKED DJD	7/14/99
RESP ENG CHB	7/14/99
MFG ENG CHB	7/14/99
QUAL ENG DJM	7/14/99