

THE INFORMATION CONTAINED IN THIS DRAWING IS THE SOLE PROPERTY OF ANDERSON POWER PRODUCTS. ANY REPRODUCTION IN PART OR WHOLE WITHOUT THE WRITTEN PERMISSION OF ANDERSON POWER PRODUCTS IS PROHIBITED.

ANDERSON POWER PRODUCTS RESERVES THE RIGHT TO ALTER PRODUCT TYPES, THEIR TECHNICAL DATA, DIMENSION, STYLE AND ACCESSORIES WITHOUT PRIOR NOTIFICATION.

DATE	**
BY:	**
DESCRIPTION OF CHANGES	**
REV.	**

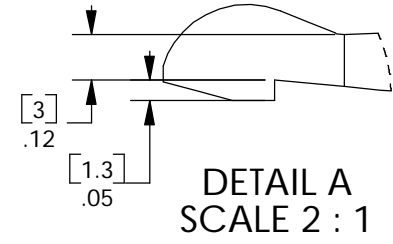
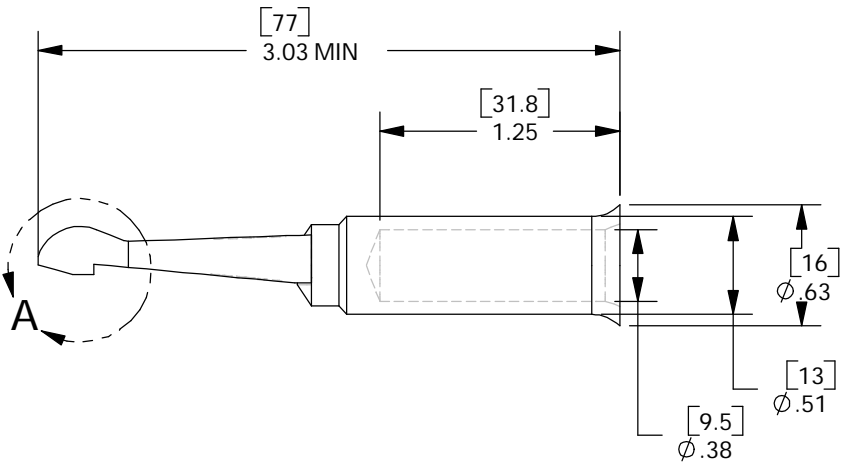
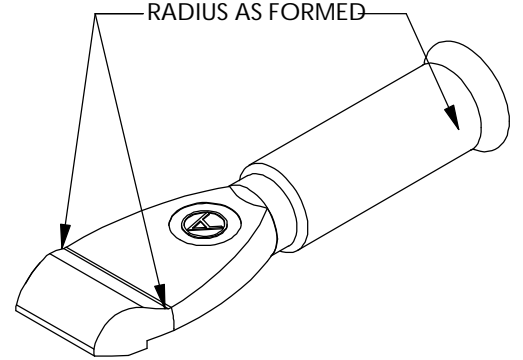
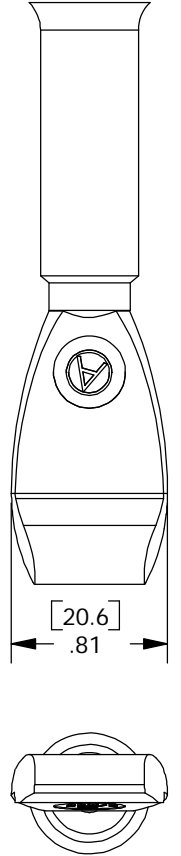

ITEM NO.	PART OR IDENTIFYING NO.	NOMENCLATURE OR DESCRIPTION	MATERIAL SPECIFICATION	QTY RECD
COPYRIGHT 2001 ANDERSON POWER PRODUCTS. ALL RIGHTS RESERVED. UNAUTHORIZED REPRODUCTION HEREBY PROHIBITED.				
DIMENSIONS ARE IN INCHES DIMENSIONS IN PARENTHESES [] ARE IN MILLIMETERS		CAD GENERATED DRAWING, DO NOT MANUALLY UPDATE	ANDERSON POWER PRODUCTS	
TOLERANCES ARE: 2PL- ±.02 [±.5]		APPROVALS	DATE	
MATERIALS: COPPER		DRAWN	CMS	1/31/02
FINISH SILVER PLATE		CHECKED	DJD	1/31/02
NEXT ASSY		RESP ENG	UFN	1/31/02
USED ON		MFG ENG	CHB	1/31/02
APPLICATION		QUAL ENG	RPO	1/31/02
DO NOT SCALE DRAWING		SIZE	A	SPECIFICATION: 114335S1
		SCALE	NONE	CADFILES/01490
				SHEET 1 OF 1

