

THE INFORMATION CONTAINED IN THIS DRAWING IS THE SOLE PROPERTY OF ANDERSON POWER PRODUCTS. ANY REPRODUCTION IN PART OR WHOLE WITHOUT THE WRITTEN PERMISSION OF ANDERSON POWER PRODUCTS IS PROHIBITED.

DATE	12/16/04
BY:	DJD
DESCRIPTION OF CHANGES	ECRN 13769: ϕ .09 WAS ϕ .08
REV.	1

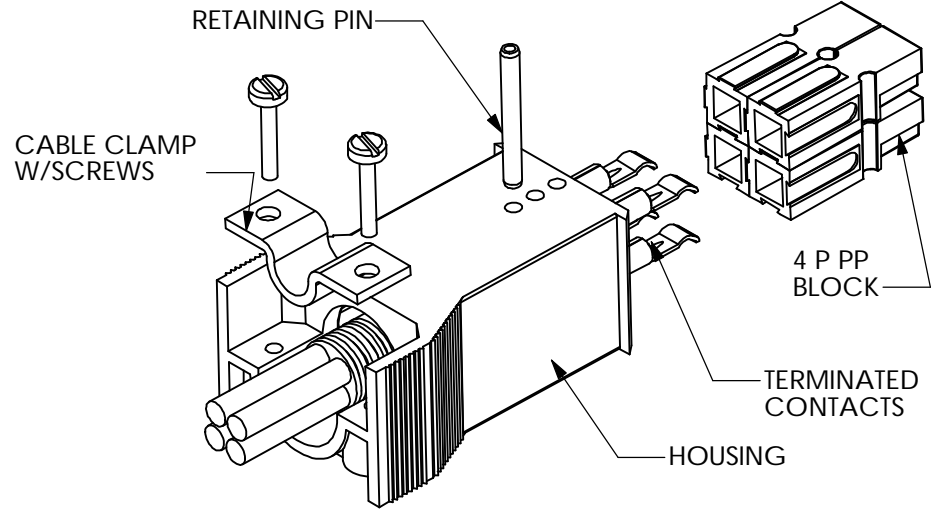

TYPICAL ASSEMBLY- REFER TO CATALOG FOR AVAILABLE CONFIGURATIONS

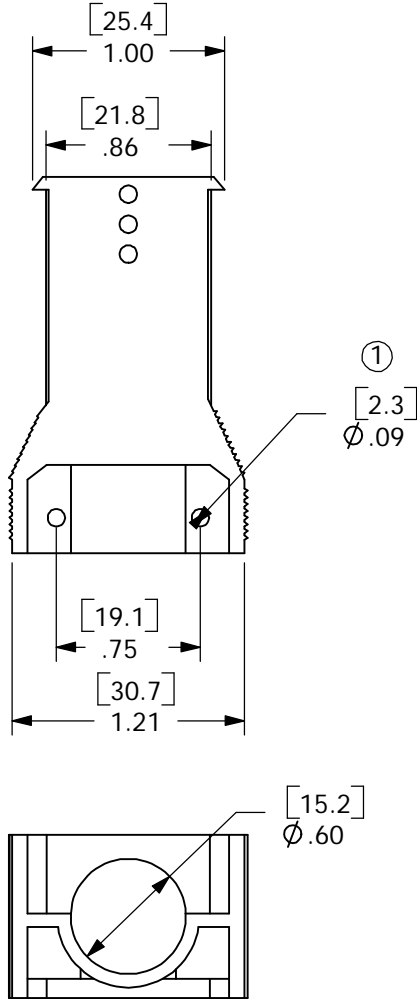
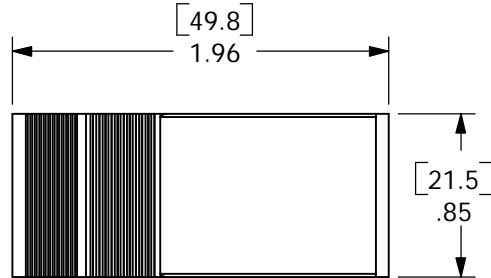

ITEM NO.	PART OR IDENTIFYING NO.	NOMENCLATURE OR DESCRIPTION	MATERIAL SPECIFICATION	QTY REOD
COPYRIGHT 1999 ANDERSON POWER PRODUCTS. ALL RIGHTS RESERVED. UNAUTHORIZED REPRODUCTION HEREBY PROHIBITED.				
DIMENSIONS ARE IN INCHES DIMENSIONS IN PARENTHESES [] ARE IN MILLIMETERS		CAD GENERATED DRAWING, DO NOT MANUALLY UPDATE		ANDERSON POWER PRODUCTS
TOLERANCES ARE: 2PL- \pm .02 [\pm .5]		APPROVALS		DATE
MATERIALS: <i>POLYCARBONATE</i>		DRAWN		CMS 8/3/99
FINISH		CHECKED		DJD 8/5/99
NONE		RESP ENG		UFN 8/13/99
NEXT ASSY	USED ON	MFG ENG		CHB 8/5/99
APPLICATION	DO NOT SCALE DRAWING	QUAL ENG		RO 8/10/99
SPECIFICATION:			REV.	
SIZE A			1	
SCALE NONE			114166S1	
CADFILES/01091			SHEET 1 OF 1	

8 7 6 5 4 3 2 1

D

C

B

A

D

C

B

A