

# CRIMPING INSTRUCTIONS FOR CATALOG # 1368 HYDRAULIC CRIMP TOOL

## General Information:

Notice: This tool is for use by a qualified technician or electrician in accordance with national and local electrical codes, Service and Operation Manual, and the following instructions.

This tool has a 4-indent style nest for crimping contacts. A locating adapter is included for crimping Anderson contacts.

## CRIMPING INSTRUCTIONS:

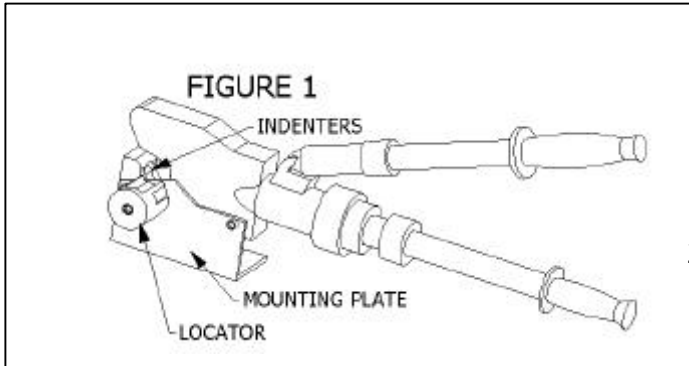

1) Rotate locator to select proper contact locator position. Use position 1 for SB type contacts.

I.e. SB-350 contact in SB-350-1 locator position, EC 2/0 contact in EC Locator position

2) Insert contact, making sure that the contact is against the back surface of the locator and flat surface of SB type contacts

rests against the bottom surface of the locator. (figure 2)

3) Crimp the contact per instructions included with the tool. Note that the locator design allows for slight movement during the crimp cycle due to the movement of crimp indentors.

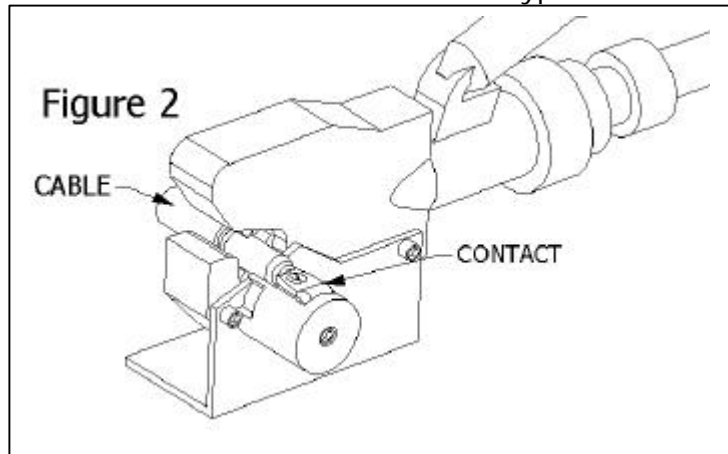

4) SB type contacts should be crimped twice. Rotate the locator to position 2 and repeat steps 2 and 3, i.e. SB-350 contact in SB-350-2 (Figure 3). Note: EC type contacts are crimped only once.

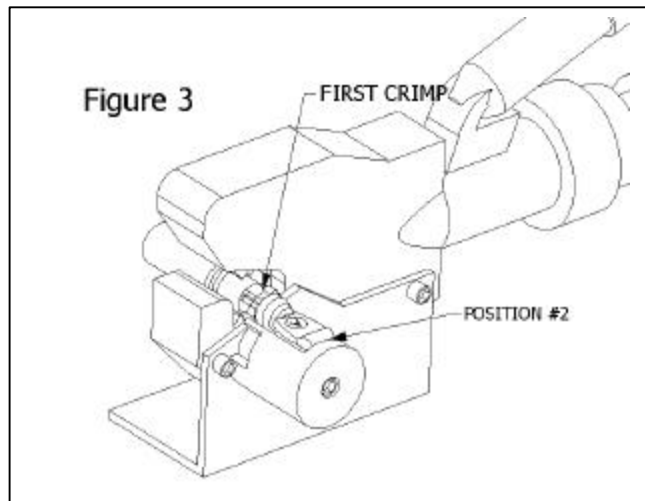

## Instructions for Mounting cat. #B00508G (VC-7 Locating Adapter)

1. Remove the two screws ( A & B) from the standard VC-7 crimp tool.
2. Position the tool as shown and mount the locator with the longer screws provided.

Please Note: For proper crimp location the shoulder screw (C) should be periodically checked for tightness.

